

SENSORS & TRANSDUCERS

6^{vol. 141}
/12

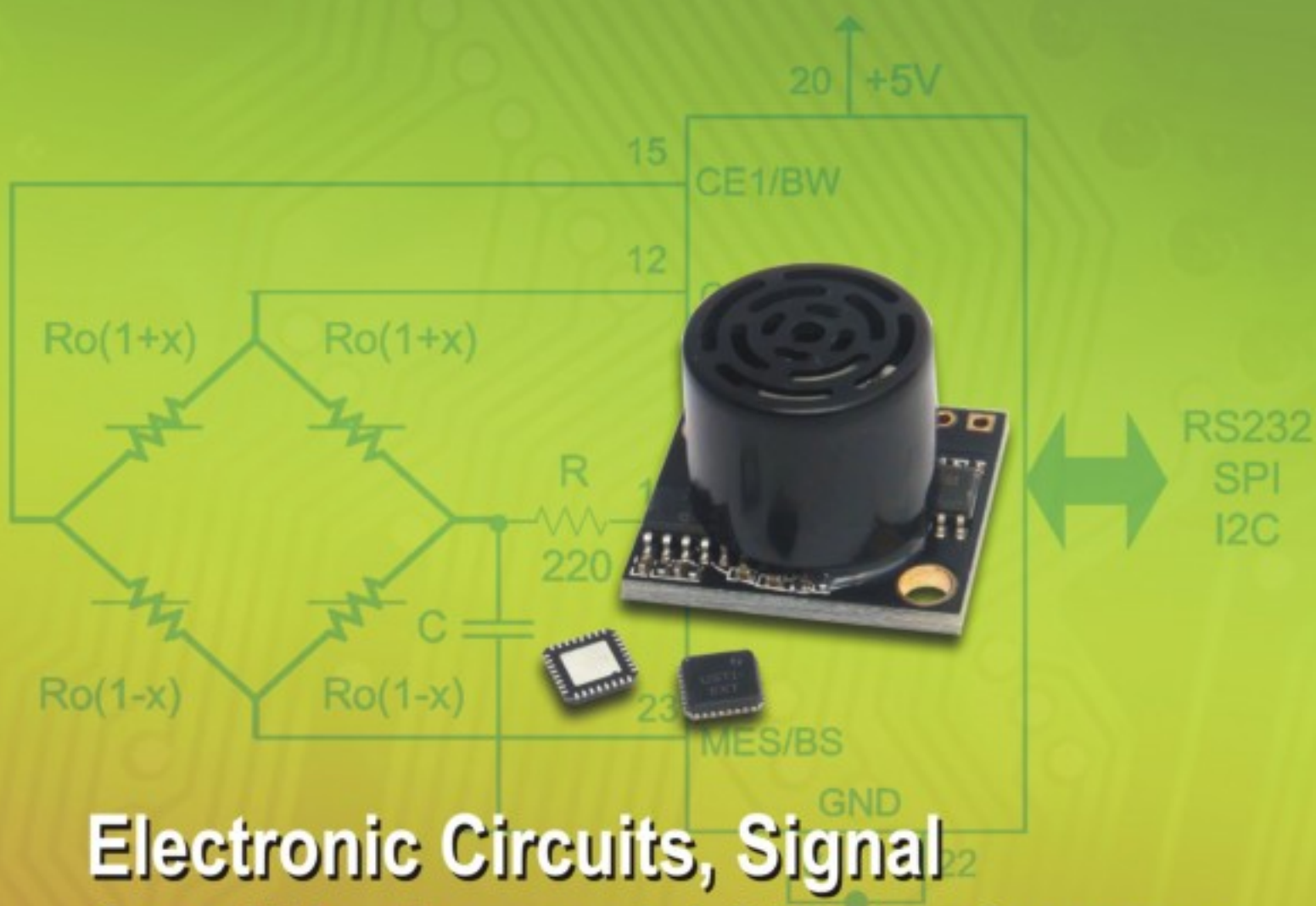

Electronic Circuits, Signal Conditioning and ASIC for Sensors

Editors-in-Chief: professor Sergey Y. Yurish, tel.: +34 696067716, e-mail: editor@sensorsportal.com**Editors for Western Europe**Meijer, Gerard C.M., Delft University of Technology, The Netherlands
Ferrari, Vittorio, Università di Brescia, Italy**Editors for North America**Datskos, Panos G., Oak Ridge National Laboratory, USA
Fabien, J. Josse, Marquette University, USA
Katz, Evgeny, Clarkson University, USA**Editor South America**

Costa-Felix, Rodrigo, Inmetro, Brazil

Editor for Eastern Europe

Sachenko, Anatoly, Ternopil State Economic University, Ukraine

Editor for Asia

Ohyama, Shinji, Tokyo Institute of Technology, Japan

Editor for Africa

Maki K.Habib, American University in Cairo, Egypt

Editor for Asia-Pacific

Mukhopadhyay, Subhas, Massey University, New Zealand

Editorial Advisory Board

- Abdul Rahim, Ruzairi**, Universiti Teknologi, Malaysia
Ahmad, Mohd Noor, Northern University of Engineering, Malaysia
Annamalai, Karthigeyan, National Institute of Advanced Industrial Science and Technology, Japan
Arcega, Francisco, University of Zaragoza, Spain
Arguel, Philippe, CNRS, France
Ahn, Jae-Pyoung, Korea Institute of Science and Technology, Korea
Arndt, Michael, Robert Bosch GmbH, Germany
Ascoli, Giorgio, George Mason University, USA
Atalay, Selcuk, Inonu University, Turkey
Atghiaee, Ahmad, University of Tehran, Iran
Augutis, Vygtantas, Kaunas University of Technology, Lithuania
Avachit, Patil Lalchand, North Maharashtra University, India
Ayesh, Aladdin, De Montfort University, UK
Azamimi, Azian binti Abdullah, Universiti Malaysia Perlis, Malaysia
Bahreyni, Behraad, University of Manitoba, Canada
Baliga, Shankar, B., General Motors Transnational, USA
Baoxian, Ye, Zhengzhou University, China
Barford, Lee, Agilent Laboratories, USA
Barlingay, Ravindra, RF Arrays Systems, India
Basu, Sukumar, Jadavpur University, India
Beck, Stephen, University of Sheffield, UK
Ben Bouzid, Sihem, Institut National de Recherche Scientifique, Tunisia
Benachaiba, Chellali, Universitè de Bechar, Algeria
Binnie, T. David, Napier University, UK
Bischoff, Gerlinde, Inst. Analytical Chemistry, Germany
Bodas, Dhananjay, IMTEK, Germany
Borges Carval, Nuno, Universidade de Aveiro, Portugal
Bouchikhi, Benachir, University Moulay Ismail, Morocco
Bousbia-Salah, Mounir, University of Annaba, Algeria
Bouvet, Marcel, CNRS – UPMC, France
Brudzewski, Kazimierz, Warsaw University of Technology, Poland
Cai, Chenxin, Nanjing Normal University, China
Cai, Qingyun, Hunan University, China
Calvo-Gallego, Jaime, Universidad de Salamanca, Spain
Campanella, Luigi, University La Sapienza, Italy
Carvalho, Vitor, Minho University, Portugal
Cecelja, Franjo, Brunel University, London, UK
Cerda Belmonte, Judith, Imperial College London, UK
Chakrabarty, Chandan Kumar, Universiti Tenaga Nasional, Malaysia
Chakravorty, Dipankar, Association for the Cultivation of Science, India
Changhai, Ru, Harbin Engineering University, China
Chaudhari, Gajanan, Shri Shivaji Science College, India
Chavali, Murthy, N.I. Center for Higher Education, (N.I. University), India
Chen, Jiming, Zhejiang University, China
Chen, Rongshun, National Tsing Hua University, Taiwan
Cheng, Kuo-Sheng, National Cheng Kung University, Taiwan
Chiang, Jeffrey (Cheng-Ta), Industrial Technol. Research Institute, Taiwan
Chiriac, Horia, National Institute of Research and Development, Romania
Chowdhuri, Arijit, University of Delhi, India
Chung, Wen-Yaw, Chung Yuan Christian University, Taiwan
Corres, Jesus, Universidad Publica de Navarra, Spain
Cortes, Camilo A., Universidad Nacional de Colombia, Colombia
Courtois, Christian, Universite de Valenciennes, France
Cusano, Andrea, University of Sannio, Italy
D'Amico, Arnaldo, Università di Tor Vergata, Italy
De Stefano, Luca, Institute for Microelectronics and Microsystem, Italy
Deshmukh, Kiran, Shri Shivaji Mahavidyalaya, Barshi, India
Dickert, Franz L., Vienna University, Austria
Dieguez, Angel, University of Barcelona, Spain
Dighavkar, C. G., M.G. Vidyamandir's L. V.H. College, India
Dimitropoulos, Panos, University of Thessaly, Greece
Ding, Jianning, Jiangsu Polytechnic University, China
Djordjevich, Alexander, City University of Hong Kong, Hong Kong
Donato, Nicola, University of Messina, Italy
Donato, Patricio, Universidad de Mar del Plata, Argentina
Dong, Feng, Tianjin University, China
Drlicja, Predrag, Instersema Sensoric SA, Switzerland
Dubey, Venketesh, Bournemouth University, UK
Enderle, Stefan, Univ. of Ulm and KTB Mechatronics GmbH, Germany
Erdem, Gursan K. Arzum, Ege University, Turkey
Erkmen, Aydan M., Middle East Technical University, Turkey
Estelle, Patrice, Insa Rennes, France
Estrada, Horacio, University of North Carolina, USA
Faiz, Adil, INSA Lyon, France
Fericean, Sorin, Balluff GmbH, Germany
Fernandes, Joana M., University of Porto, Portugal
Francioso, Luca, CNR-IMM Institute for Microelectronics and Microsystems, Italy
Francis, Laurent, University Catholique de Louvain, Belgium
Fu, Weiling, South-Western Hospital, Chongqing, China
Gaura, Elena, Coventry University, UK
Geng, Yanfeng, China University of Petroleum, China
Gole, James, Georgia Institute of Technology, USA
Gong, Hao, National University of Singapore, Singapore
Gonzalez de la Rosa, Juan Jose, University of Cadiz, Spain
Granell, Annette, Goteborg University, Sweden
Graff, Mason, The University of Texas at Arlington, USA
Guan, Shan, Eastman Kodak, USA
Guillet, Bruno, University of Caen, France
Guo, Zhen, New Jersey Institute of Technology, USA
Gupta, Narendra Kumar, Napier University, UK
Hadjiloucas, Sillas, The University of Reading, UK
Haider, Mohammad R., Sonoma State University, USA
Hashsham, Syed, Michigan State University, USA
Hasni, Abdelhafid, Bechar University, Algeria
Hernandez, Alvaro, University of Alcalá, Spain
Hernandez, Wilmar, Universidad Politecnica de Madrid, Spain
Homentcovschi, Dorel, SUNY Binghamton, USA
Horstman, Tom, U.S. Automation Group, LLC, USA
Hsiai, Tzung (John), University of Southern California, USA
Huang, Jeng-Sheng, Chung Yuan Christian University, Taiwan
Huang, Star, National Tsing Hua University, Taiwan
Huang, Wei, PSG Design Center, USA
Hui, David, University of New Orleans, USA
Jaffrezic-Renault, Nicole, Ecole Centrale de Lyon, France
James, Daniel, Griffith University, Australia
Janting, Jakob, DELTA Danish Electronics, Denmark
Jiang, Liudi, University of Southampton, UK
Jiang, Wei, University of Virginia, USA
Jiao, Zheng, Shanghai University, China
John, Joachim, IMEC, Belgium
Kalach, Andrew, Voronezh Institute of Ministry of Interior, Russia
Kang, Moonho, Sunmoon University, Korea South
Kaniasas, Eugenijus, Vienna University of Technology, Austria
Katake, Anup, Texas A&M University, USA
Kausel, Wilfried, University of Music, Vienna, Austria
Kavasoglu, Nese, Mugla University, Turkey
Ke, Cathy, Tyndall National Institute, Ireland
Khelfaoui, Rachid, Université de Bechar, Algeria
Khan, Asif, Aligarh Muslim University, Aligarh, India
Kim, Min Young, Kyungpook National University, Korea South
Ko, Sang Choon, Electronics. and Telecom. Research Inst., Korea South
Kotulska, Malgorzata, Wroclaw University of Technology, Poland
Kockar, Hakan, Balikesir University, Turkey
Kong, Ing, RMIT University, Australia
Kratz, Henrik, Uppsala University, Sweden

Krishnamoorthy, Ganesh, University of Texas at Austin, USA
Kumar, Arun, University of Delaware, Newark, USA
Kumar, Subodh, National Physical Laboratory, India
Kung, Chih-Hsien, Chang-Jung Christian University, Taiwan
Lacnjevac, Caslav, University of Belgrade, Serbia
Lay-Ekuakille, Aime, University of Lecce, Italy
Lee, Jang Myung, Pusan National University, Korea South
Lee, Jun Su, Amkor Technology, Inc. South Korea
Lei, Hua, National Starch and Chemical Company, USA
Li, Fengyuan (Thomas), Purdue University, USA
Li, Genxi, Nanjing University, China
Li, Hui, Shanghai Jiaotong University, China
Li, Sihua, Agiltron, Inc., USA
Li, Xian-Fang, Central South University, China
Li, Yuefa, Wayne State University, USA
Liang, Yuanchang, University of Washington, USA
Liawruangrath, Saisunee, Chiang Mai University, Thailand
Liew, Kim Meow, City University of Hong Kong, Hong Kong
Lin, Hermann, National Kaohsiung University, Taiwan
Lin, Paul, Cleveland State University, USA
Linderholm, Pontus, EPFL - Microsystems Laboratory, Switzerland
Liu, Aihua, University of Oklahoma, USA
Liu Changgeng, Louisiana State University, USA
Liu, Cheng-Hsien, National Tsing Hua University, Taiwan
Liu, Songqin, Southeast University, China
Lodeiro, Carlos, University of Vigo, Spain
Lorenzo, Maria Encarnacio, Universidad Autonoma de Madrid, Spain
Lukaszewicz, Jerzy Pawel, Nicholas Copernicus University, Poland
Ma, Zhanfang, Northeast Normal University, China
Majstorovic, Vidosav, University of Belgrade, Serbia
Malyshev, V.V., National Research Centre 'Kurchatov Institute', Russia
Marquez, Alfredo, Centro de Investigacion en Materiales Avanzados, Mexico
Matay, Ladislav, Slovak Academy of Sciences, Slovakia
Mathur, Prafull, National Physical Laboratory, India
Maurya, D.K., Institute of Materials Research and Engineering, Singapore
Mekid, Samir, University of Manchester, UK
Melnyk, Ivan, Photon Control Inc., Canada
Mendes, Paulo, University of Minho, Portugal
Mennell, Julie, Northumbria University, UK
Mi, Bin, Boston Scientific Corporation, USA
Minas, Graca, University of Minho, Portugal
Mishra, Vivekanand, National Institute of Technology, India
Moghavvemi, Mahmoud, University of Malaya, Malaysia
Mohammadi, Mohammad-Reza, University of Cambridge, UK
Molina Flores, Esteban, Benemérita Universidad Autónoma de Puebla, Mexico
Moradi, Majid, University of Kerman, Iran
Morello, Rosario, University "Mediterranea" of Reggio Calabria, Italy
Mounir, Ben Ali, University of Sousse, Tunisia
Mrad, Nezhil, Defence R&D, Canada
Mulla, Imtiaz Sirajuddin, National Chemical Laboratory, Pune, India
Nabok, Aleksey, Sheffield Hallam University, UK
Neelamegam, Periasamy, Sastra Deemed University, India
Neshkova, Milka, Bulgarian Academy of Sciences, Bulgaria
Oberhammer, Joachim, Royal Institute of Technology, Sweden
Ould Lahoucine, Cherif, University of Guelma, Algeria
Pamidighanta, Sayanu, Bharat Electronics Limited (BEL), India
Pan, Jisheng, Institute of Materials Research & Engineering, Singapore
Park, Joon-Shik, Korea Electronics Technology Institute, Korea South
Passaro, Vittorio M. N., Politecnico di Bari, Italy
Penza, Michele, ENEA C.R., Italy
Pereira, Jose Miguel, Instituto Politecnico de Seteбал, Portugal
Petsev, Dimiter, University of New Mexico, USA
Pogacnik, Lea, University of Ljubljana, Slovenia
Post, Michael, National Research Council, Canada
Prance, Robert, University of Sussex, UK
Prasad, Ambika, Gulbarga University, India
Prateepasen, Asa, Kingmoungut's University of Technology, Thailand
Pugno, Nicola M., Politecnico di Torino, Italy
Pullini, Daniele, Centro Ricerche FIAT, Italy
Pumera, Martin, National Institute for Materials Science, Japan
Radhakrishnan, S., National Chemical Laboratory, Pune, India
Rajanna, K., Indian Institute of Science, India
Ramadan, Qasem, Institute of Microelectronics, Singapore
Rao, Basuthkar, Tata Inst. of Fundamental Research, India
Raouf, Kosai, Joseph Fourier University of Grenoble, France
Rastogi Shiva, K., University of Idaho, USA
Reig, Candid, University of Valencia, Spain
Restivo, Maria Teresa, University of Porto, Portugal
Robert, Michel, University Henri Poincare, France
Rezazadeh, Ghader, Urmia University, Iran
Royo, Santiago, Universitat Politècnica de Catalunya, Spain
Rodriguez, Angel, Universitat Politècnica de Catalunya, Spain
Rothberg, Steve, Loughborough University, UK
Sadana, Ajit, University of Mississippi, USA
Sadeghian Marnani, Hamed, TU Delft, The Netherlands
Sapozhnikova, Ksenia, D.I.Mendeleyev Institute for Metrology, Russia
Sandacci, Serghei, Sensor Technology Ltd., UK
Saxena, Vibha, Bbhba Atomic Research Centre, Mumbai, India
Schneider, John K., Ultra-Scan Corporation, USA
Sengupta, Deepak, Advance Bio-Photonics, India
Seif, Selemani, Alabama A & M University, USA
Seifter, Achim, Los Alamos National Laboratory, USA
Shah, Kriyang, La Trobe University, Australia
Sankarraaj, Anand, Detector Electronics Corp., USA
Silva Giroa, Pedro, Technical University of Lisbon, Portugal
Singh, V. R., National Physical Laboratory, India
Slomovitz, Daniel, UTE, Uruguay
Smith, Martin, Open University, UK
Soleymanpour, Ahmad, University of Toledo, USA
Somani, Prakash R., Centre for Materials for Electronics Technol., India
Sridharan, M., Sastra University, India
Srinivas, Talabattula, Indian Institute of Science, Bangalore, India
Srivastava, Arvind K., NanoSonix Inc., USA
Stefan-van Staden, Raluca-Ioana, University of Pretoria, South Africa
Stefanescu, Dan Mihai, Romanian Measurement Society, Romania
Sumriddetchka, Sarun, National Electronics and Comp. Technol. Center, Thailand
Sun, Chengliang, Polytechnic University, Hong-Kong
Sun, Dongming, Jilin University, China
Sun, Junhua, Beijing University of Aeronautics and Astronautics, China
Sun, Zhiqiang, Central South University, China
Suri, C. Raman, Institute of Microbial Technology, India
Syssoev, Victor, Saratov State Technical University, Russia
Szewczyk, Roman, Industr. Research Inst. for Automation and Measurement, Poland
Tan, Ooi Kiang, Nanyang Technological University, Singapore
Tang, Dianping, Southwest University, China
Tang, Jaw-Luen, National Chung Cheng University, Taiwan
Teker, Kasif, Frostburg State University, USA
Thirunavukkarasu, I., Manipal University Karnataka, India
Thumbavanam Pad, Kartik, Carnegie Mellon University, USA
Tian, Gui Yun, University of Newcastle, UK
Tsiantos, Vassilios, Technological Educational Institute of Kaval, Greece
Tsigara, Anna, National Hellenic Research Foundation, Greece
Twomey, Karen, University College Cork, Ireland
Valente, Antonio, University, Vila Real, - U.T.A.D., Portugal
Vanga, Raghav Rao, Summit Technology Services, Inc., USA
Vaseashta, Ashok, Marshall University, USA
Vazquez, Carmen, Carlos III University in Madrid, Spain
Vieira, Manuela, Instituto Superior de Engenharia de Lisboa, Portugal
Vigna, Benedetto, STMICROELECTRONICS, Italy
Vrba, Radimir, Brno University of Technology, Czech Republic
Wandelt, Barbara, Technical University of Lodz, Poland
Wang, Jiangping, Xi'an Shiyong University, China
Wang, Kedong, Beihang University, China
Wang, Liang, Pacific Northwest National Laboratory, USA
Wang, Mi, University of Leeds, UK
Wang, Shinn-Fwu, Ching Yun University, Taiwan
Wang, Wei-Chih, University of Washington, USA
Wang, Wensheng, University of Pennsylvania, USA
Watson, Steven, Center for NanoSpace Technologies Inc., USA
Weiping, Yan, Dalian University of Technology, China
Wells, Stephen, Southern Company Services, USA
Wolkenberg, Andrzej, Institute of Electron Technology, Poland
Woods, R. Clive, Louisiana State University, USA
Wu, DerHo, National Pingtung Univ. of Science and Technology, Taiwan
Wu, Zhaoyang, Hunan University, China
Xiu Tao, Ge, Chuzhou University, China
Xu, Lisheng, The Chinese University of Hong Kong, Hong Kong
Xu, Sen, Drexel University, USA
Xu, Tao, University of California, Irvine, USA
Yang, Dongfang, National Research Council, Canada
Yang, Shuang-Hua, Loughborough University, UK
Yang, Wuqiang, The University of Manchester, UK
Yang, Xiaoling, University of Georgia, Athens, GA, USA
Yaping Dan, Harvard University, USA
Ymeti, Aurel, University of Twente, Netherland
Yong Zhao, Northeastern University, China
Yu, Haihu, Wuhan University of Technology, China
Yuan, Yong, Massey University, New Zealand
Yufera Garcia, Alberto, Seville University, Spain
Zakaria, Zulkarnay, University Malaysia Perlis, Malaysia
Zagnoni, Michele, University of Southampton, UK
Zamani, Cyrus, Universitat de Barcelona, Spain
Zeni, Luigi, Second University of Naples, Italy
Zhang, Minglong, Shanghai University, China
Zhang, Qintao, University of California at Berkeley, USA
Zhang, Weiping, Shanghai Jiao Tong University, China
Zhang, Wenming, Shanghai Jiao Tong University, China
Zhang, Xueji, World Precision Instruments, Inc., USA
Zhong, Haoxiang, Henan Normal University, China
Zhu, Qing, Fujifilm Dimatix, Inc., USA
Zorzano, Luis, Universidad de La Rioja, Spain
Zourob, Mohammed, University of Cambridge, UK

Contents

Volume 141
Issue 6
June 2012

www.sensorsportal.com

ISSN 1726-5479

Editorial

IFSA Publishing Starts to Publish Hardcover and Paperback Books

Sergey Y. Yurish, Editor-in-Chief 1

Research Articles

Research in Nanothermometry Part 4. Amorphous Alloys of Thermo-resistive Thermometry

Bohdan Stadnyk, Svyatoslav Yatsyshyn, Pylyp Skoropad..... 1

Research in Nanothermometry. Part 5. Noise Thermometry and Nature of Substance

Svyatoslav Yatsyshyn, Bohdan Stadnyk, Zinoviy Kolodiy..... 8

Design of Linearized Thermistor Connection Circuit Using Modified 555 Timer

Narayana K. V. L. and Bhujanga Rao A..... 17

Design and Development of Microcontroller Based Photoacoustic Spectrometer

P. Bhaskar, Immanuel J., and Bhagyajyoti..... 26

The Design of a New Instrument for Pen-contact Force Information Acquisition During Handwriting

Jianfei Luo, Baoyuan Wu, Qiushi Lin, Zhongcheng Wu, Fei Shen 35

ARM Cortex Processor Based Closed Loop Servo Motor Position Control System

Madhusudhana Reddy Narayanareddygari, Nagabhushan Raju. K, Chandra Mouli. C., Chandrasekhar Reddy Devanna 45

The Hardware Design Technique for Ultrasonic Process Tomography System

Mohd Hafiz Fazalul Rahiman, Ruzairi Abdul Rahim, Herlina Abdul Rahim and Nor Muzakkir Nor Ayob 52

Design, Development and Testing of a Semi Cylindrical Capacitive Sensor for Liquid Flow Rate Measurement in Process Industry

Sagarika Pal, Sharmi Ganguly 62

Synchronization Based SAW Sensor Using Delay Line Coupled Dual Oscillator Phase Dynamics

Shashank S. Jha and R. D. S. Yadava 71

Intelligent Robust Nonlinear Controller for MEMS Angular Rate Sensor

Mohammad-Reza Moghanni-Bavil-Olyaei, Ahmad Ghanbari, Jafar Keighobadi 92

Analysis of the Self-Calibration Process in a Displacement Sensor in Applications of Hip or Knee Implants

Shiying Hao 106

Acoustic Detector for Determining the Type and Concentration of a Solution <i>Tariq Younes</i>	119
Low Concentration Sodium Chloride Salinity Detection System <i>Hee C. Lim, Hio Giap Ooi, Yew Fong Hor</i>	127
ARM Processor Based Embedded System for Examination Question Paper Leakage Protection System <i>Jyothi Pattipati, Chandra Mouli Chakala, Chaitanya Pavan Kanchisamudram, Nagaraja Chiyedu and Nagabhushan Raju Konduru</i>	134

Authors are encouraged to submit article in MS Word (doc) and Acrobat (pdf) formats by e-mail: editor@sensorsportal.com
Please visit journal's webpage with preparation instructions: <http://www.sensorsportal.com/HTML/DIGEST/Submission.htm>

International Frequency Sensor Association (IFSA).



Handbook of Laboratory Measurements and Instrumentation

Maria Teresa Restivo
Fernando Gomes de Almeida
Maria de Fátima Chouzal
Joaquim Gabriel Mendes
António Mendes Lopes

The Handbook of Laboratory Measurements and Instrumentation presents experimental and laboratory activities with an approach as close as possible to reality, even offering remote access to experiments, providing to the reader an excellent tool for learning laboratory techniques and methodologies. Book includes dozens videos, animations and simulations following each of chapters. It makes the title very valued and different from existing books on measurements and instrumentation.

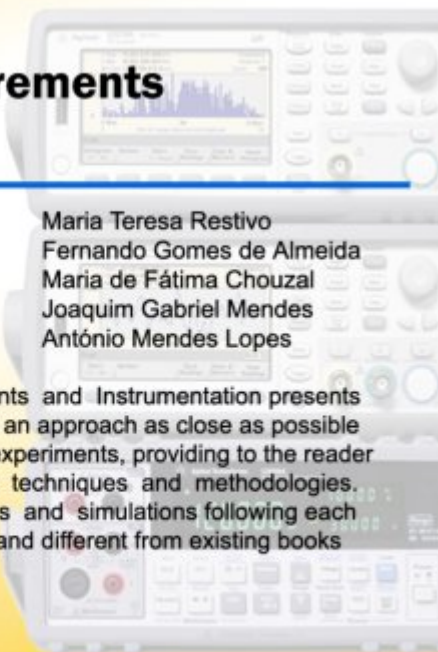



International Frequency Sensor Association Publishing

Order online:
http://www.sensorsportal.com/HTML/BOOKSTORE/Handbook_of_Measurements.htm

ARM Processor Based Embedded System for Examination Question Paper Leakage Protection System

¹ Jyothi PATTIPATI, ¹ Chandra Mouli CHAKALA,
² Chaitanya Pavan KANCHISAMUDRAM, ¹ Nagaraja CHIYEDU
and ¹ Nagabhushan Raju KONDURU

¹ Department of Instrumentation, Sri Krishnadevaraya University,
Anantapur, 515 003, India

Tel.: 08554 – 255744

² Megabyte Technologies, Bangalore

Tel.: +91 9739915434

E-mail: jyothi_mayi99@yahoo.com, researchermouli@gmail.com, k.chaitanyapavan@gmail.com,
c_nagaraja@yahoo.co.uk and knrbhushan@yahoo.com

Received: 9 Mach 2012 /Accepted: 25 June 2012 /Published: 30 June 2012

Abstract: Question paper leakage is one of the main issues for the students, who suffer from the postponement or cancellation of examination. The compact solution for this problem is ARM processor based examination paper leakage protection system. The question paper comes to the college in an electronic sealed box called ibox. The ibox contains an embedded system that was designed using ARM processor, which contains inbuilt RTC to monitor the ibox. If anyone tries to open the ibox before and after the RFID (Radio Frequency Identification) swipe time duration, the system reports to university authorities by sending an SMS (Short Message Service) through GSM (Global System for Mobile communication) that “some malfunctioning is happening with the ibox”. Before 10 minutes of exam the university authorities sends a unique pass code to the chief examiner of the college. The chief examiner has a valid RFID card from the university and swipes the card. If the card is valid the system acknowledges for the pass code. Chief examiner needs to type the pass code using keyboard. If pass code is correct stepper motor rotates and unlocks the ibox. The system is having two sections of transceivers (A and B). The transceiver A is an embedded system associated with the ibox. The transceiver B is the mobile phone with the university authorities. The present work deals with the software and hardware part. *Copyright © 2012 IFSA.*

Keywords: ARM Processor, GSM, SMS, RFID, Embedded System.

1. Introduction

An embedded system is a combination of software and hardware which is designed for one specific application in a time domain constraint. Now-a-days the meaning of the embedded system was changed because, it was not designed only for one specific application but, many applications can run with a single embedded system. The best example of an embedded system is a mobile phone which performs the communication, along with the communication one can surf the internet, access the social network sites, play the games and even global positioning system is deployed into such a small device.

Until a few years ago, general-purpose processors and computers have been the driving force in shaping the digital economy. A general purpose processor is a microprocessor which incorporates the functions of a computer's central processing unit on a single integrated circuit. Technically speaking microprocessors need more hardware to interface and to interact with the other peripheral devices. Microprocessors do not have I/O lines, on-chip memory, timers, counters etc... next the 8-bit microcontrollers are designed with all mentioned peripherals was integrated into a single chip. These 8-bit microcontrollers are designed for both parallel and serial communication purpose. Then lot of microcontrollers are designed which categorizes like 8-bit, 16-bit and 32-bit microcontrollers.

There are many reasons, both technical and market driven to select one processor over another. In a lot of embedded-type applications the device encompasses functionality other than simply high speed data processing, such as a user interface, communications, or mechanical device control. The present work can be carried out by using 8-bit microcontroller but more hardware is required in the form of external peripherals and connecting them to work as an embedded system.

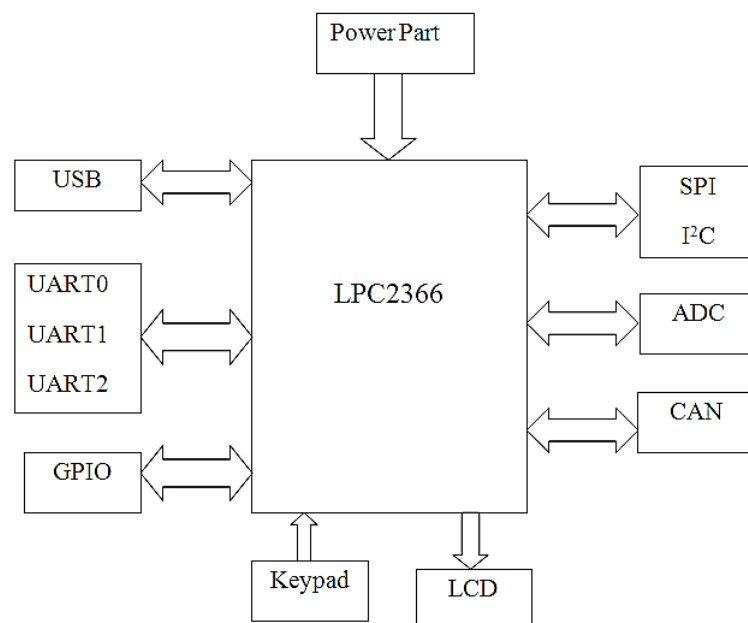

Fig. 1. Block Diagram of LPC2366 Development Board.

The ARM architecture is the most widely used 32-bit instruction set architecture microcontroller. Many chips with ARM processors include peripherals A/D converters, counter/timers, capacitive touch controllers, LCD controllers, USB, Wi-Fi baseband, etc. They already built into the chip, a way to disable peripherals when they are not being used, saving power without having to add extra power management components. The wider variety of ARM processors means that, it is likely to find one,

which includes the functionality that needs for the device already built-in to the chip rather than having to add a second chip for that function. This saves on peripheral cost, design time, and physical space on the circuit board. Despite the variety in peripherals, the internal processor itself remains mostly the same across the variations, still allowing for economy of scale for development tools, and a large enough community of developers to find peer support for technical questions.

During the time of examination, students get depressed of finding the news in the television or newspaper about question paper leakage and hence the exam was postponed / cancelled. In order to prevent this question paper leakage, a compact and portable solution was designed using advanced RISC machine. ARM processor based microcontroller used in the present study is LPC2366, which is Low Power Consumption controller from NXP Phillips. LPC2366 has in built 10 bit ADC, 3 UARTs, 70 GPIOs, 10 bit DAC, 4 timers/ counters, RTC, watch dog timer (WDT), etc. Using these in built peripherals the designing of paper leakage protection system achieves its portability. Other peripherals like GSM modem, RFID module, keypad, LCD and stepper motor are used in this system.

2. Hardware Description

Designing of hardware is an essential part to implement any embedded system. In the present work hardware peripherals LPC2366, RFID (Radio Frequency Identification) module, GSM (Global System for Mobile Communication) module, Keypad and stepper motor are used.

Fig. 1 shows the block diagram of the LPC2366 development board. The development board contains power part, USB (Universal Serial Bus) port, 3 UARTs (Universal Asynchronous Receiver and Transmitter), GPIOs (General Purpose Input Output), 4X4 Hex Keypad, LCD (Liquid Crystal Display), 2 CAN (Controller Area Network) ports, ADC (Analog to Digital Converter) connector, etc. Power part provides power supply to the board from a 12 V adapter.

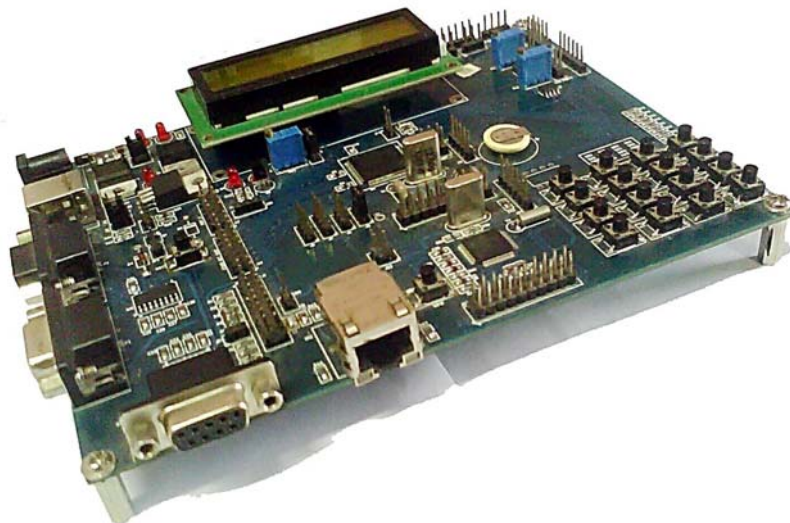

Fig. 2. LPC2366 ARM Development Board.

The power part regulates the 12 V power supply to 3.3 V by using the regulator ICs 7805 and LM1117T. In order to provide power supply to the board one can use the USB port also. Three UARTs namely UART0, UART1 and UART2 is used to make serial communication with the outside world. In the present work UART0 is used to dump the hex file from PC to microcontroller and after that, it is

connected to the RFID module. UART1 is connected to the GSM module. UART2 is left unused. LPC2366 have 70 GPIOs in which 7 lines are used to interface with LCD, 8 lines are used to interface with keypad and 4 lines are used to interface with the driver circuit of stepper motor. SPI, I²C, ADC and CAN are left unused.

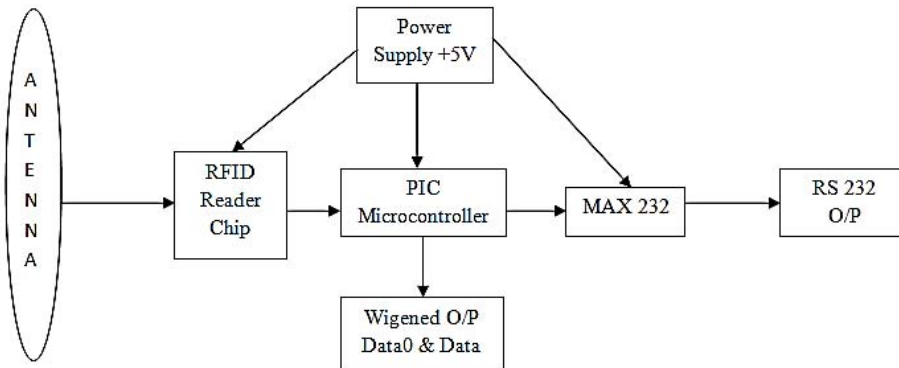

Fig. 3. Block Diagram of RFID Reader.

Fig. 3 shows the block diagram of RFID Reader. There are two main components used by the RFID module: The Interrogator (RFID Reader) which transmits and receives the signal and the Transponder (tag) that is attached to the object. Communication between the RFID Reader and tag occurs wirelessly and generally does not require a line of sight between the devices. The RFID Reader emits a low-power radio wave field which is used to power up the tag so as to pass on any information that is contained on the chip.

- Antenna generates 125KHZ frequency which is used to read the data in RFID tag.
- RFID Reader reads the data present in RFID tag.
- PIC Microcontroller decodes the data into Serial output and wig end output.
- MAX232 is used to convert signal from TTL to RS232.

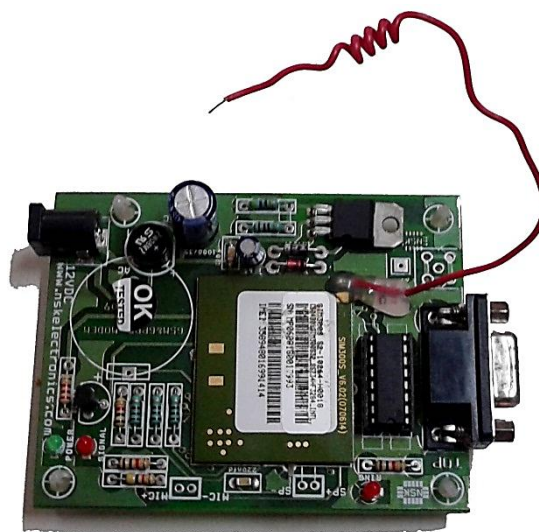

Fig. 4. GSM Modem Module.

The GSM modem used by cell phones that provides low cost, long range, wireless communication channel for applications that need connectivity rather than high data rates. The interface between GSM and ARM controller is a textual protocol called Hayes AT- Commands. This particular application connects an ARM controller and Siemens M65 cellular phone using a RS232 based data cable. Fig. 4 shows the photograph of GSM modem module.

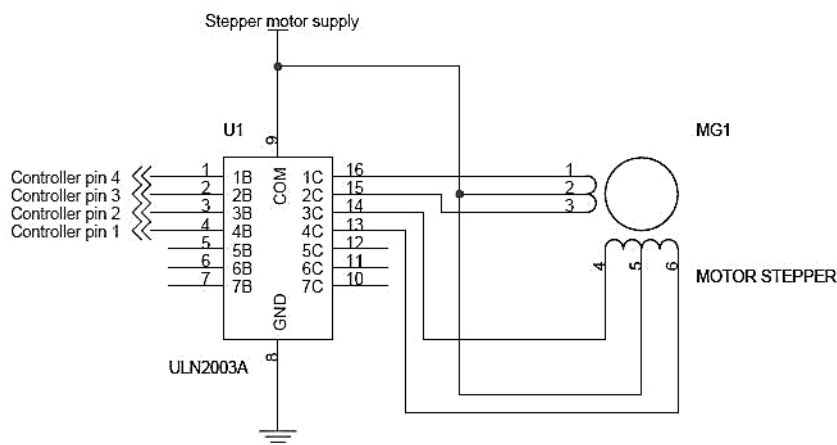

Fig. 5. Schematic Diagram of ULN2003A and Stepper Motor.

Fig. 5 shows the circuit diagram of interfacing of controller and stepper motor through ULN2003A. In the present study the stepper motor was used as the locking mechanism. A lock mechanism including a lock lever movable between unlocked and locked positions, the lock lever being connected to further components of the lock mechanism to provide for corresponding unlocked and locked conditions of the lock mechanism, the lock lever being operably movable between the unlocked and locked positions by a stepper motor and through a drive path by a automatically actuatable element. The drive path includes ULN2003A and connected to the stepper motor as shown in Fig. 5. LPC2366 pins P0.4 (controller pin1) through P0.7 (controller pin4) was connected to ULN2003A.

3. System Functionality

The system consists of two transceiver sections, transceiver A and transceiver B. Fig. 6 shows the block diagram of transceiver A i.e. ARM processor based embedded system for question paper leakage protection system and transceiver B is a mobile with the university authorities. Transceiver A consists of LPC2366 which was interfaced with Keypad, GSM, LCD, stepper motor and RFID modules.

The RFID and GSM modules are connected to the UART0 and UART1 respectively. The LPC2366 port pins P0.2 (TX0) and P0.3 (RX0) are connected to pin11 and pin12 of MAX232 to made UART0 work for code firing. The LPC2366 port pins P0.15 (TX1) and P0.16 (RX1) are connected to pin10 and pin9 of MAX232 16 pin IC to made UART1 work. In the present work LCD was connected and programmed to 4 data lines (D0 – D4) of LPC2366 i.e. P1.24 through P1.29. Keypad was connected to the port lines P2.0 through P2.7, and Stepper motor driver ULN2003A was connected to the port lines P0.4 through P0.7 of LPC2366.

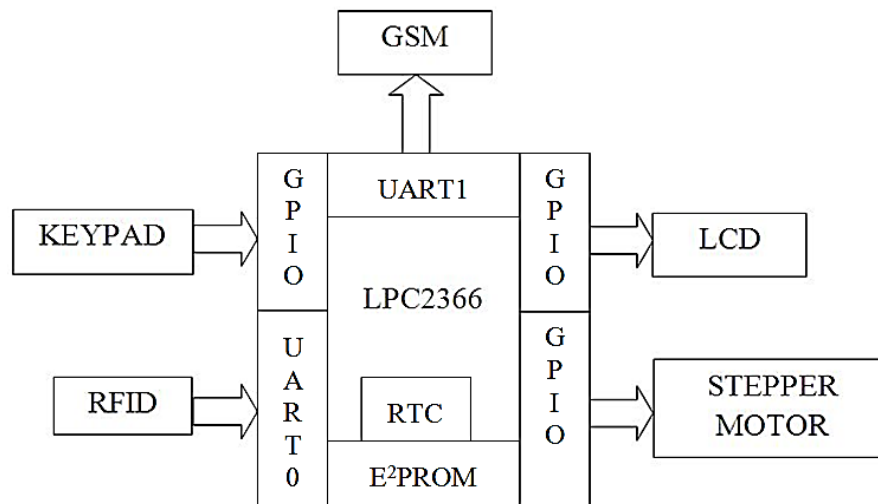

Fig. 6. Block Diagram of ARM Processor Based Question Paper Leakage Protection System.

The system was programmed in “Embedded C” language. The software flow chart was shown in the Fig. 7. A unique GSM pass code from the university authorities was sent to the chief examiner of the college. GPIO’s, UART0, UART1, RTC and E²PROM’s were initialized. At power on, LCD, GSM initializes and displays "EXAM PAPER LEAK PROTECTION". The RTC of LPC2366 was programmed in such a way to run the present local time and it is displayed on the LCD. The E²PROM was stored with RFID tag address “20747628”, GSM pass code “B2389”, examination date and time of the examination. 10 min duration was kept within which the operation must complete. Let us assume that the card swipe time duration was loaded as 9am to 9:10am. If the RFID card swipes before 9am then “INVALID TIME” displays on the LCD and the system sends a message to the predefined mobile number of university authorities. The card was swiped between 9am and 9:10am which is a valid time and “VALID CARD” displays on LCD. After swiping the card the unique pass code should enter through the keypad of the system. If the RFID tag address and GSM pass code which is entered and that stored on E²PROM matches, then the stepper motor rotates to open the ibox. Hence, the question papers are safe from theft before examination. If the card is swiped before 9am or after 9.10am it will be invalid.

4. Results

The photograph of the present work was shown in Fig. 8. The design and implementation of ARM processor based examination question paper leakage system was effectively carried out with the advantages of low cost, low power consumption, high portability and minimum peripheral interfaces. The system was tested with the RFID card swipe time duration from 9am to 9:10am. The response of the system is good and successfully tested all the conditions mentioned in the system functionality. Test conditions include:

1. Invalid RFID card swiped and the system was not responded and displayed the message “INVALID CARD” on LCD.
2. RFID card was valid and GSM pass code was wrong then system displayed “PASS CODE ERROR” and message was sent to +91-9160425798.
3. Both RFID and GSM pass code were valid; the system granted access and stepper motor rotated (to open the ibox).
4. When RFID card was swiped before 9am and after 9:10am the system displayed “UNAUTHORIZED ACCESS” and message was sent to +91-9160425798.

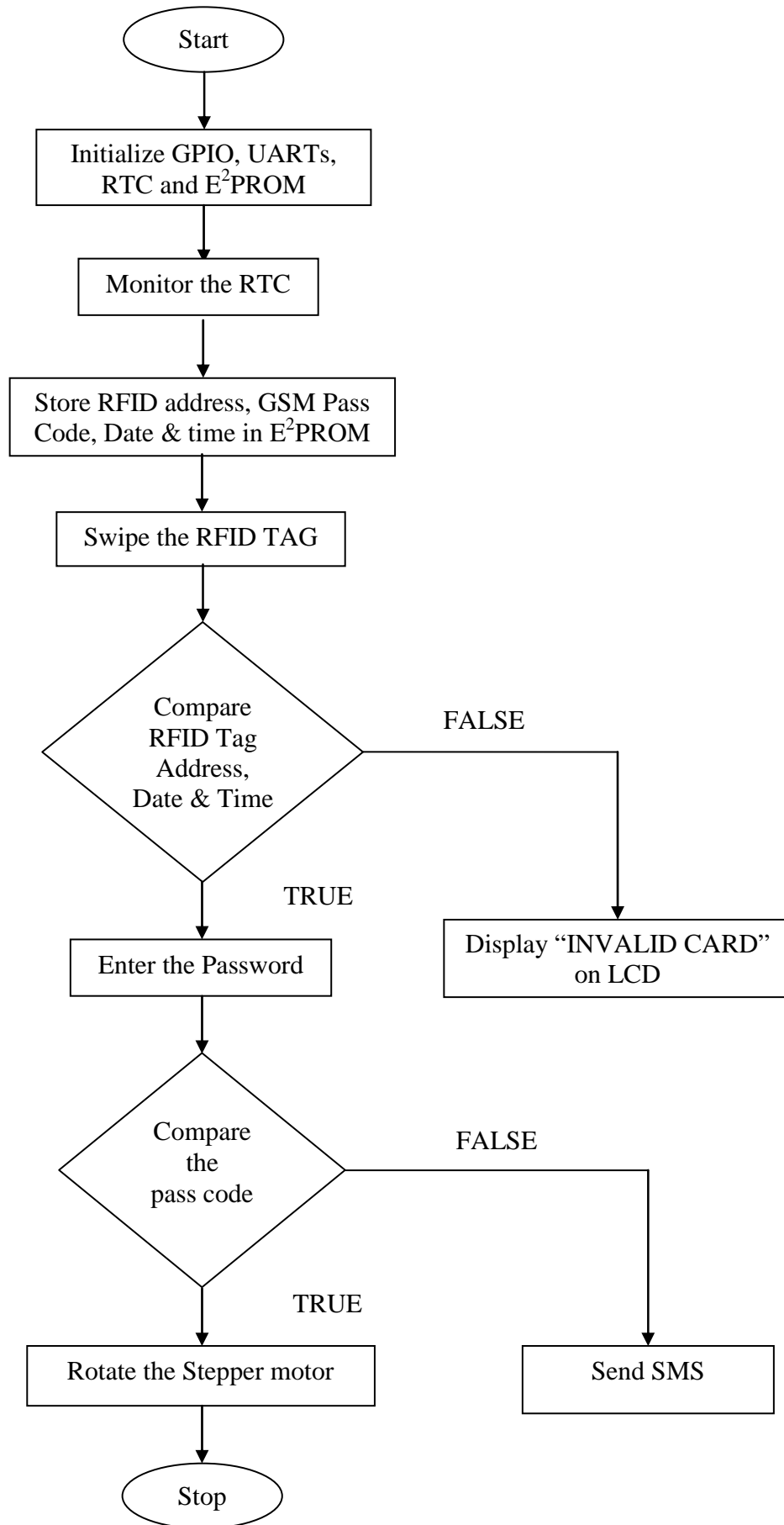

Fig. 7. Flow Chart of the Software.

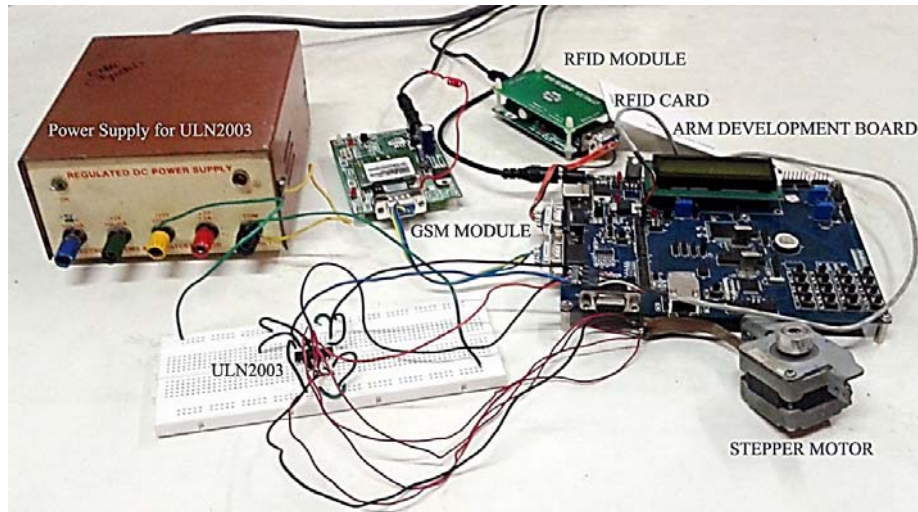

Fig. 8. Photograph of ARM Processor Based Question Paper Leakage Protection System.

5. Conclusions

The compact solution for the examination paper leakage was achieved with ARM based embedded controller. The present work can be extended to protect the answer sheets to send it to the university authorities. The embedded system can be programmed to close the ibox after the completion of the exam.

Acknowledgements

The authors acknowledge the help and support of Mega Byte Technologies, Bangalore for providing the facilities for carrying out the research work.

References

- [1]. Muhammad Ali Mazidi, Janice Gillespie Mazidi and Rolin D. McKinlay , The 8051 Microcontroller and Embedded Systems using Assembly and C, 2nd Edition, *PHI*.
- [2]. David Seal, ARM Architecture Reference Manual, 2nd Edition, *Addison Wesley*.
- [3]. Andrew N. Sloss, Dominic Symes, Chris Wright, ARM System Developer's Guide: Designing and Optimizing System Software, 2nd Edition, *Elsevier*.
- [4]. C. Nagaraja, C. Chandra Mouli, S. Athavulla, and T. Bheemalingaiah, A Microcontroller Based Programmable Power Supply, *Lab Experiments – A Journal of Laboratory Experiments*, Vol. 10, No. 4, December 2010, pp. 249-253.
- [5]. C. Chandra Mouli, V. Ramnath, D. Sailaja, and K. Nagabhushan Raju, Embedded System Based Exhaust Fan Control, *Lab Experiments – A Journal of Laboratory Experiments*, Vol. 11, No. 3, September 2011, pp. 200-201.
- [6]. LPC2366 data sheet (http://docweb.khk.be/Patrick%20Colleman/ARM7/lpc236x_ds.pdf).
- [7]. LPC2366 User Manual (http://www.keil.com/dd/docs/datashts/philips/lpc23xx_um.pdf).
- [8]. Pentagram Technologies (<http://www.pentagramtechnologies.com/m13s2.html>).

The 3rd International Conference on Sensor Device Technologies and Applications



SENSORDEVICES 2012

19 - 24 August 2012 - Rome, Italy

Deadline for papers: 5 April 2012



Tracks: Sensor devices - Ultrasonic and Piezosensors - Photonics - Infrared - Geosensors - Sensor device technologies - Sensors signal conditioning and interfacing circuits - Medical devices and sensors applications - Sensors domain-oriented devices, technologies, and applications - Sensor-based localization and tracking technologies

<http://www.aria.org/conferences2012/SENSORDEVICES12.html>

The 6th International Conference on Sensor Technologies and Applications



SENSORCOMM 2012

19 - 24 August 2012 - Rome, Italy

Deadline for papers: 5 April 2012



Tracks: Architectures, protocols and algorithms of sensor networks - Energy, management and control of sensor networks - Resource allocation, services, QoS and fault tolerance in sensor networks - Performance, simulation and modelling of sensor networks - Security and monitoring of sensor networks - Sensor circuits and sensor devices - Radio issues in wireless sensor networks - Software, applications and programming of sensor networks - Data allocation and information in sensor networks - Deployments and implementations of sensor networks - Under water sensors and systems - Energy optimization in wireless sensor networks

<http://www.aria.org/conferences2012/SENSORCOMM12.html>

The 5th International Conference on Advances in Circuits, Electronics and Micro-electronics



CENICS 2012

19 - 24 August 2012 - Rome, Italy

Deadline for papers: 5 April 2012



Tracks: Semiconductors and applications - Design, models and languages - Signal processing circuits - Arithmetic computational circuits - Microelectronics - Electronics technologies - Special circuits - Consumer electronics - Application-oriented electronics

<http://www.aria.org/conferences2012/CENICS12.html>

Guide for Contributors

Aims and Scope

Sensors & Transducers Journal (ISSN 1726-5479) provides an advanced forum for the science and technology of physical, chemical sensors and biosensors. It publishes state-of-the-art reviews, regular research and application specific papers, short notes, letters to Editor and sensors related books reviews as well as academic, practical and commercial information of interest to its readership. Because of it is a peer reviewed international journal, papers rapidly published in *Sensors & Transducers Journal* will receive a very high publicity. The journal is published monthly as twelve issues per year by International Frequency Sensor Association (IFSA). In addition, some special sponsored and conference issues published annually. *Sensors & Transducers Journal* is indexed and abstracted very quickly by Chemical Abstracts, IndexCopernicus Journals Master List, Open J-Gate, Google Scholar, etc. Since 2011 the journal is covered and indexed (including a Scopus, Embase, Engineering Village and Reaxys) in Elsevier products.

Topics Covered

Contributions are invited on all aspects of research, development and application of the science and technology of sensors, transducers and sensor instrumentations. Topics include, but are not restricted to:

- Physical, chemical and biosensors;
- Digital, frequency, period, duty-cycle, time interval, PWM, pulse number output sensors and transducers;
- Theory, principles, effects, design, standardization and modeling;
- Smart sensors and systems;
- Sensor instrumentation;
- Virtual instruments;
- Sensors interfaces, buses and networks;
- Signal processing;
- Frequency (period, duty-cycle)-to-digital converters, ADC;
- Technologies and materials;
- Nanosensors;
- Microsystems;
- Applications.

Submission of papers

Articles should be written in English. Authors are invited to submit by e-mail editor@sensorsportal.com 8-14 pages article (including abstract, illustrations (color or grayscale), photos and references) in both: MS Word (doc) and Acrobat (pdf) formats. Detailed preparation instructions, paper example and template of manuscript are available from the journal's webpage: <http://www.sensorsportal.com/HTML/DIGEST/Submission.htm> Authors must follow the instructions strictly when submitting their manuscripts.

Advertising Information

Advertising orders and enquires may be sent to sales@sensorsportal.com Please download also our media kit: http://www.sensorsportal.com/DOWNLOADS/Media_Kit_2012.pdf

Digital Sensors and Sensor Systems: Practical Design will greatly benefit undergraduate and at PhD students, engineers, scientists and researchers in both industry and academia. It is especially suited as a reference guide for practitioners, working for Original Equipment Manufacturers (OEM) electronics market (electronics/hardware), sensor industry, and using commercial-off-the-shelf components, as well as anyone facing new challenges in technologies, and those involved in the design and creation of new digital sensors and sensor systems, including smart and/or intelligent sensors for physical or chemical, electrical or non-electrical quantities.

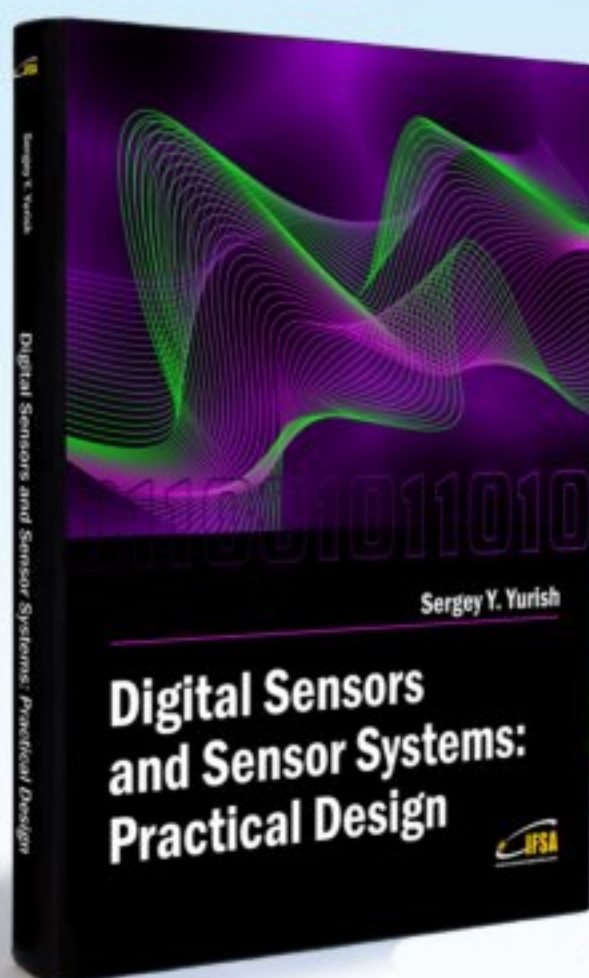

"It is an outstanding and most completed practical guide about how to deal with frequency, period, duty-cycle, time interval, pulse width modulated, phase-shift and pulse number output sensors and transducers and quickly create various low-cost digital sensors and sensor systems ..." (from a review)

Order online:

http://www.sensorsportal.com/HTML/BOOKSTORE/Digital_Sensors.htm



www.sensorsportal.com