

ISSN 1726-5749

SENSORS & TRANSDUCERS

12^{vol. 74}/06

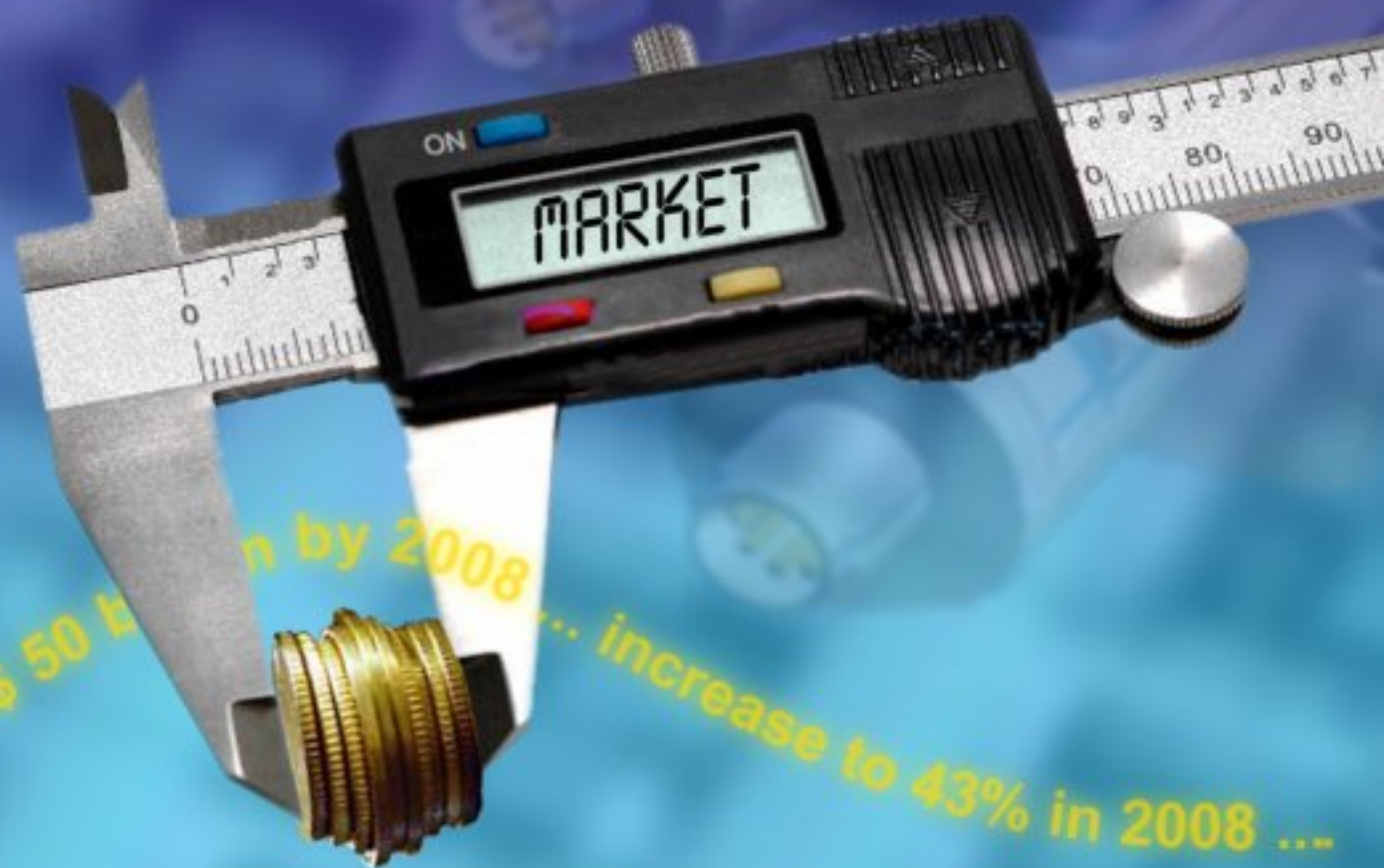

Sensor Market Trends

International Frequency Sensor Association Publishing





Sensors & Transducers

Volume 74
Issue 12
December 2006

www.sensorsportal.com

ISSN 1726-5479

Editor-in-Chief: professor Sergey Y. Yurish, phone: +34 696067716, e-mail: editor@sensorsportal.com

Editorial Advisory Board

- Ahn, Jae-Pyoung**, Korea Institute of Science and Technology, Korea
Arndt, Michael, Robert Bosch GmbH, Germany
Atghiaee, Ahmad, University of Tehran, Iran
Augutis, Vygtantas, Kaunas University of Technology, Lithuania
Avachit, Patil Lalchand, North Maharashtra University, India
Bahreyni, Behraad, University of Manitoba, Canada
Barford, Lee, Agilent Laboratories, USA
Barlingay, Ravindra, Priyadarshini College of Engineering and Architecture, India
Basu, Sukumar, Jadavpur University, India
Beck, Stephen, University of Sheffield, UK
Ben Bouzid, Sihem, Institut National de Recherche Scientifique, Tunisia
Bodas, Dhananjay, IMTEK, Germany
Bousbia-Salah, Mounir, University of Annaba, Algeria
Brudzewski, Kazimierz, Warsaw University of Technology, Poland
Cerda Belmonte, Judith, Imperial College London, UK
Chakrabarty, Chandan Kumar, Universiti Tenaga Nasional, Malaysia
Chen, Rongshun, National Tsing Hua University, Taiwan
Chiriac, Horia, National Institute of Research and Development, Romania
Chung, Wen-Yaw, Chung Yuan Christian University, Taiwan
Cortes, Camilo A., Universidad de La Salle, Colombia
Costa-Felix, Rodrigo, Inmetro, Brazil
Cusano, Andrea, University of Sannio, Italy
D'Amico, Arnaldo, Università di Tor Vergata, Italy
Dickert, Franz L., Vienna University, Austria
Dieguez, Angel, University of Barcelona, Spain
Ding Jian, Ning, Jiangsu University, China
Donato, Nicola, University of Messina, Italy
Donato, Patricio, Universidad de Mar del Plata, Argentina
Dong, Feng, Tianjin University, China
Drljaca, Predrag, Instersema Sensoric SA, Switzerland
Erdem, Gursan K. Arzum, Ege University, Turkey
Erkmen, Aydan M., Middle East Technical University, Turkey
Estrada, Horacio, University of North Carolina, USA
Fericean, Sorin, Balluff GmbH, Germany
Gaura, Elena, Coventry University, UK
Gole, James, Georgia Institute of Technology, USA
Gonzalez de la Ros, Juan Jose, University of Cadiz, Spain
Guan, Shan, Eastman Kodak, USA
Gupta, Narendra Kumar, Napier University, UK
Hernandez, Wilmar, Universidad Politecnica de Madrid, Spain
Homentcovschi, Dorel, SUNY Binghamton, USA
Hsiai, Tzung (John), University of Southern California, USA
Jaffrezic-Renault, Nicole, Ecole Centrale de Lyon, France
Jaime Calvo-Galleg, Jaime, Universidad de Salamanca, Spain
James, Daniel, Griffith University, Australia
Janting, Jakob, DELTA Danish Electronics, Denmark
Jiang, Liudi, University of Southampton, UK
Jiao, Zheng, Shanghai University, China
John, Joachim, IMEC, Belgium
Kalach, Andrew, Voronezh Institute of Ministry of Interior, Russia
Katake, Anup, Texas A&M University, USA
Lacnjevac, Caslav, University of Belgrade, Serbia
Li, Genxi, Nanjing University, China
Lin, Hermann, National Kaohsiung University, Taiwan
Lin, Paul, Cleveland State University, USA
Liu, Cheng-Hsien, National Tsing Hua University, Taiwan
Liu, Songqin, Southeast University, China
Lorenzo, Maria Encarnacio, Universidad Autonoma de Madrid, Spain
Matay, Ladislav, Slovak Academy of Sciences, Slovakia
Mekid, Samir, University of Manchester, UK
Mi, Bin, Boston Scientific Corporation, USA
Moghavvemi, Mahmoud, University of Malaya, Malaysia
Mohammadi, Mohammad-Reza, University of Cambridge, UK
Mukhopadhyay, Subhas, Massey University, New Zealand
Neelamegam, Periasamy, Sastra Deemed University, India
Neshkova, Milka, Bulgarian Academy of Sciences, Bulgaria
Oberhammer, Joachim, Royal Institute of Technology, Sweden
Ohyama, Shinji, Tokyo Institute of Technology, Japan
Pereira, Jose Miguel, Instituto Politecnico de Seteabal, Portugal
Petsev, Dimitir, University of New Mexico, USA
Pogacnik, Lea, University of Ljubljana, Slovenia
Pratepasen, Asa, Kingmoungut's University of Technology, Thailand
Pullini, Daniele, Centro Ricerche FIAT, Italy
Pumera, Martin, National Institute for Materials Science, Japan
Rajanna, K., Indian Institute of Science, India
Reig, Candid, University of Valencia, Spain
Robert, Michel, University Henri Poincare, France
Rodriguez, Angel, Universidad Politecnica de Catalunya, Spain
Rothberg, Steve, Loughborough University, UK
Royo, Santiago, Universitat Politecnica de Catalunya, Spain
Sadana, Ajit, University of Mississippi, USA
Sapozhnikova, Ksenia, D.I.Mendeleyev Institute for Metrology, Russia
Saxena, Vibha, Bhabha Atomic Research Centre, Mumbai, India
Shearwood, Christopher, Nanyang Technological University, Singapore
Shin, Kyuho, Samsung Advanced Institute of Technology, Korea
Shmaliy, Yuriy, Kharkiv National University of Radio Electronics, Ukraine
Silva Girao, Pedro, Technical University of Lisbon Portugal
Slomovitz, Daniel, UTE, Uruguay
Stefan-van Staden, Raluca-Ioana, University of Pretoria, South Africa
Sysoev, Victor, Saratov State Technical University, Russia
Thumbavanam Pad, Kartik, Carnegie Mellon University, USA
Tsiantos, Vassilios, Technological Educational Institute of Kaval, Greece
Twomey, Karen, University College Cork, Ireland
Vaseashta, Ashok, Marshall University, USA
Vigna, Benedetto, STMicroelectronics, Italy
Vrba, Radimir, Brno University of Technology, Czech Republic
Wandelt, Barbara, Technical University of Lodz, Poland
Wang, Liang, Advanced Micro Devices, USA
Wang, Wei-Chih, University of Washington, USA
Woods, R. Clive, Louisiana State University, USA
Xu, Tao, University of California, Irvine, USA
Yang, Dongfang, National Research Council, Canada
Ymeti, Aurel, University of Twente, Netherland
Zeni, Luigi, Second University of Naples, Italy
Zhou, Zhi-Gang, Tsinghua University, China
Zourob, Mohammed, University of Cambridge, UK

Contents

Volume 74
Issue 12
December 2006

www.sensorsportal.com

ISSN 1726-5479

Research Articles

Monitoring of High Pressure with Fiber Optic Sensor <i>Pandey N.K., Yadav B.C., Tripathi Anupam.....</i>	834
Experimental Validation of Fluorescence Intensity Ratio /Fluorescence Lifetime Temperature Sensing Technique <i>Vineet Kumar Rai and S. B. Rai.....</i>	839
Sensors and Methods for Electromagnetic Pulse Identification <i>Pavel Fiala, Petr Drexler.....</i>	844
Characterization Technique of an Excited Solid-State Piezoelectric Transformer as a Function of Transient Time <i>Selemani Seif.....</i>	855
Methanol Sensing Behavior of Strontium(II) Added MgAl₂O₄ Composites Through Solid-State Electrical Conductivity Measurements <i>Judith Vijaya, L. John Kennedy, G. Sekaran, K.S. Nagaraja.....</i>	864
Surface Activated ZnO Thick Film Resistors for LPG Gas Sensing <i>D.R. Patil, L.A. Patil, G.H. Jain, M.S. Wagh, S.A. Patil.....</i>	874

Authors are encouraged to submit article in MS Word (doc) and Acrobat (pdf) formats by e-mail: editor@sensorsportal.com
Please visit journal webpage with preparation instruction: <http://www.sensorsportal.com/HTML/DIGEST/Submission.htm>

Sensors and Methods for Electromagnetic Pulse Identification

¹Pavel FIALA, ²Petr DREXLER

Department of Theoretical and Experimental Electrical Engineering

Brno University of Technology, Kolejní 2906/4, 612 00 Brno, Czech Republic

¹fialap@feec.vutbr.cz, ²xdrex100@stud.feec.vutbr.cz, <http://www.utee.feec.vutbr.cz>

Received: 5 December 2006 / Accepted: 26 December 2006 / Published: 29 December 2006

Abstract: There are some suitable methods for the measurement of ultra-short solitary electromagnetic pulses that can be generated by high power pulsed generators. The measurement methods properties have to correspond to the fact whether we want to measure pulses of voltage, current or free-space electromagnetic wave. The need for specific measurement methods occurred by the development of high power microwave pulse generator [1]. Applicable methods are presented in this paper. The method utilizing Faraday's induction law allows the measurement of generated current. For the same purpose the magneto-optic method can be utilized, with its advantages. For measurement of output microwave pulse of the generator the calorimetric method was designed and realized.

Keywords: Electromagnetic pulse; High power microwave generator; Calorimetric method; Magneto-optical effect; Vircator

1. Introduction

Fig. 1. shows the basic principle of microwave pulsed power generator. It consists of three stages – the primary source of electrical energy, the pulsed power generator and the microwave pulsed power generator (load in the Fig. 1). The primary source supplies the pulsed power generator, which ensures the pulse current amplification. After transformation to the high voltage and pulse shaping (not shown in Fig. 1) the pulse is fed to the microwave pulsed power generator. The detailed description of pulsed power generation can be found in [2].

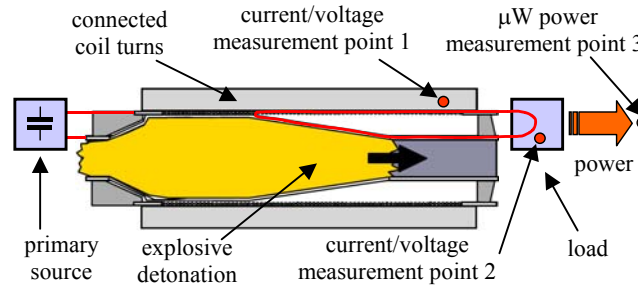

Fig. 1. The basic principle of microwave pulsed power generator.

For example, the peak level of current pulse achieves the value of $I_p = 100$ kA with the pulse duration $t_d = 70$ μ s typically in the second stage. After high voltage transformation and using pulse shaping element we can get voltage pulse with the peak value $U_p = 400$ kV and with the rise time $t_r = 0,1$ ns. Following microwave source (vircator [3]) emits electromagnetic pulse (EMP). The characteristic of EMP is high power level ($P_{max} = 250$ MW [1]) and very short time duration ($t_p \in <1, 60>$ ns).

For the pulsed power generator evaluation is essential to obtain an idea about the qualitative and quantitative processes during the generator operation. Important measurement points are shown in Fig. 1. Special requirements for measurement methods have to be considered because of the specific pulses properties.

2. Methods for Pulses Identification

The basic quantity of interest is the current of the pulsed power generator. It is quite difficult to use the classical methods for current measurement (shunt) because of the high current level. The measurement of the induced magnetic field has been proposed, according to the Faraday's induction law.

The most straightforward way for the voltage pulse measurement is the method using high voltage divider. It has been developed inductance-free high voltage divider. This divider is suitable for single shot application [4].

The final product of the relativistic vircator effect [3] is the electromagnetic pulse, which can be guided in a cylindrical waveguide or emitted in to the free-space. However, it was not possible to use microwave probe or antenna for first vircator test. The frequency range and the mode distribution were unknown. The calorimetric measurement method was proposed for the vircator tests. We can't get the pulse waveform using the calorimetric method. On the other side, it allows physically correct power and energy measurement. The power of the EMP is the crucial parameter, which gives an idea about vircator optimal design.

2.1 Method based on Faraday's induction law

Current measurement method is based on the application of the Faraday's induction law where the pulse is located by sensor (coil with $N_s = 1 \div 50$ turns). The signal induced in the coil is led to the recording device, generally an oscilloscope. Due to safety requirements, the distance between the sensor and the oscilloscope is $l = 50$ m. This parameter introduces quality decrease of the recorded information in the way of the signal amplitude reduction, change of the signal phase and the pulse

prolongation.

The elimination of this limitation is in Method I, depicted in Fig. 2., made by backward correction exploiting the Laplace transform. Pulses up to limit pulse length $T_{\max} = 1$ ns were measured by this method and magnetic flux ϕ was evaluated [1].

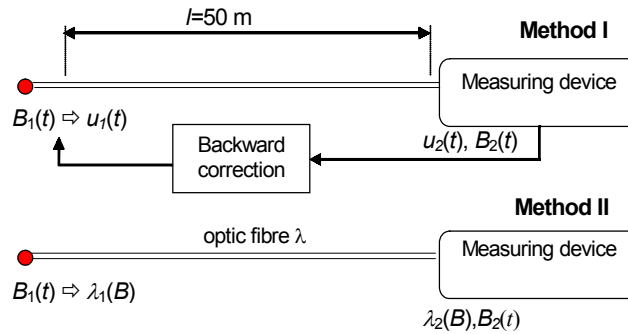

Fig. 2. Principles of the methods based on Faraday’s induction law and magneto-optic effect.

Fig. 3. shows installation of the sensor coils on the generator prototype by its test. Coils are of Rogowski type and they are connected via coaxial cable to the recording device. The example of the current pulse waveform obtained by the first experiments with coil sensor is shown in Fig. 4.

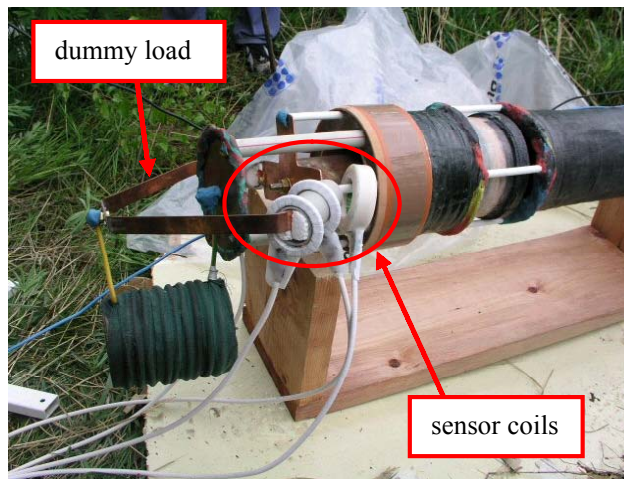

Fig. 3. Installation of the sensor coils by the pulsed power generator test.

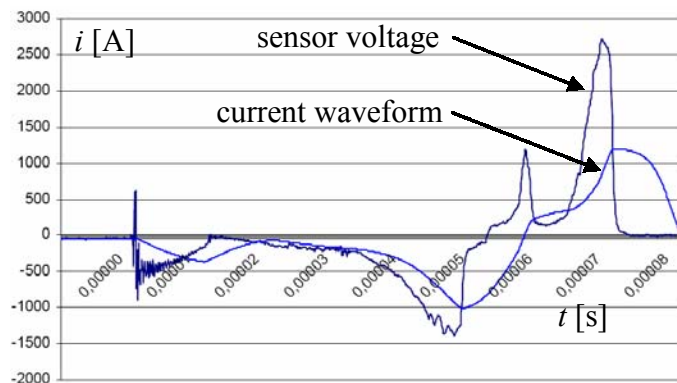

Fig. 4. Example of the current pulse waveform.

2.2 Method based on magneto/electro-optic effect

The second method presented – the magneto-optic method - uses the Faraday’s magneto-optic (Kerr’s electro-optic) effect as a sensor principle. The sensor utilizing the magneto-optic method is in development. The connection between the sensor and the measuring device is implemented in the optical wavelength as shown in Fig. 2.

There are three basic types of the possible active sensors. The first type is a garnet with high Verdet constant, the second one is an optic fiber and the third one is based on magneto-optic properties of ferromagnetic mono/multi thin film. Other types of Version IV sensors are based on the magneto-optic Kerr’s effects (MOKE), or surface MOKE (SMOKE) effect. By an available measuring devices application we can measure pulses with the limit length up to $T_{max} = 0.01$ ns [5] for repetitive pulse train.

2.3 Calorimetric methods

The above mentioned methods indicate the electromagnetic parts of the wave – electric or magnetic. They don’t express the power conditions of the electromagnetic wave. For some of the measurement it is essential to evaluate power flow through the defined area.

The group of calorimetric methods represents another type of converter to be introduced. We can measure power supplied by pulse (Poynting’s vector when we use the calorimetric converter. The sensor is connected to the measuring device (oscilloscope) by a coaxial cable of $l = 50$ m length. Fig. 5. depicts four versions of the method utilizing calorimetric measurement.

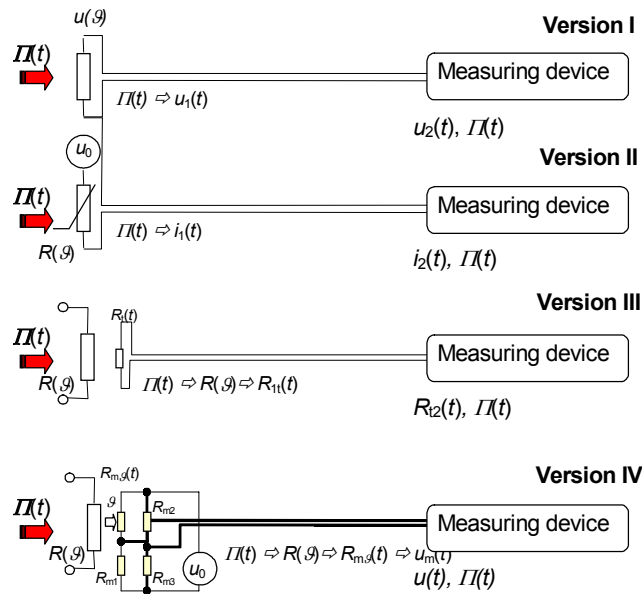

Fig. 5. Calorimetric measurement of the solitary pulse power.

Version I discussed in [6], [7] has a sensor in the form of an ideal resistor and enables measurement of the maximum value of microwave power P_{max} . The analyzed peak voltage corresponds to peak value of power P_{max} . For available measuring devices we can measure pulses with the limit length $T_{max} = 50$ ps.

Version II scans the change of resistance of the sensor, created by an evaporated thin layer, in

dependence on the pulse energy. For available measuring devices we can reach the accuracy of 30 % up to impulse limit length $T_{\max} = 0.1$ ns.

Version III is based on the measurement of the temperature change of the thermistor placed in contact with the layer. Under the same conditions as for the previous version we can reach the accuracy improvement of an order of magnitude.

Version IV is the bridge connection of version III. Several thermistors are attached in series to the evaporated layer; then, three resistors create a DC bridge of Weston type with the thermistors. The change of resistance in the thermistor arm is evaluated. The voltage in the measuring bridge diagonal is consequently integrated. Thus, the value of the pulse energy is obtained (and recorded by the measuring device). For available measuring devices we can measure pulses with the limit length $T_{\max} = 0.03$ ns with accuracy to 10 %.

3. Realization of the Calorimetric Sensor

The calorimetric sensor was of the disc design. The carbon with changed crystal lattice was designed for use as one of the thin layer types. The prototype of the sensor was designed for the measurement of vircator with output power of $P_{\max} = 250$ MW, length of pulse $t_p \in <10, 60>$ ns. Vircator is a pulse high-energy source of microwave energy based on the virtual cathode effect; its experimental construction is shown in Fig. 6. Fig.7. shows the waveform of vircator's anode current by initiation.

The concept was designed after consultation [8] for the supposed power and pulse length with room for absorption and damping of the possible back EMG wave.



Fig. 6. Experimental construction of vircator, $P_{\max} = 250$ MW.

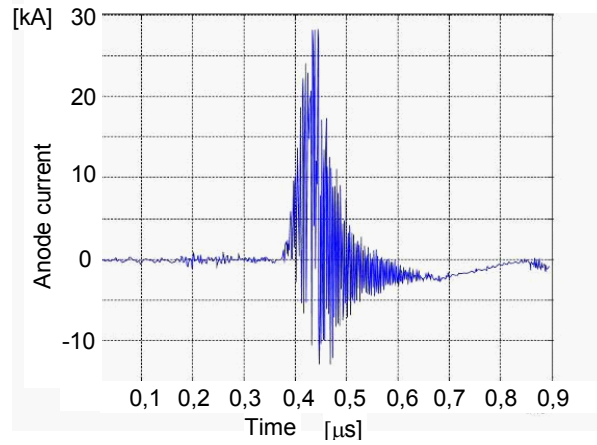

Fig. 7. Waveform of vircator's anode current.

3.1 Waveguide-fitted calorimetric sensor

The first prototype of the calorimetric sensor was intended for waveguide connection with a microwave vircator. Fig. 8 depicts the principle scheme of the calorimetric sensor design. Fig.9. shows its outer shell. The purpose of the sensor was to measure the energy (power) of the emitted EMP. It was not possible to use the probe because the modes of the field, waveform and spectrum were not known.

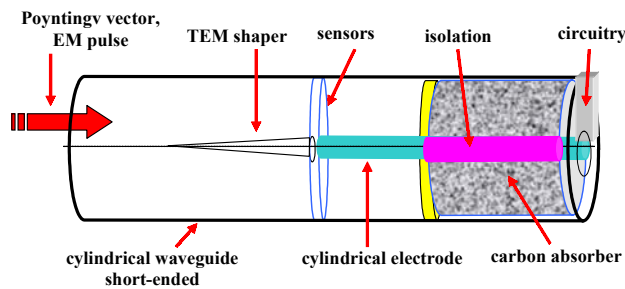

Fig. 8. Principal scheme of the calorimetric sensor.

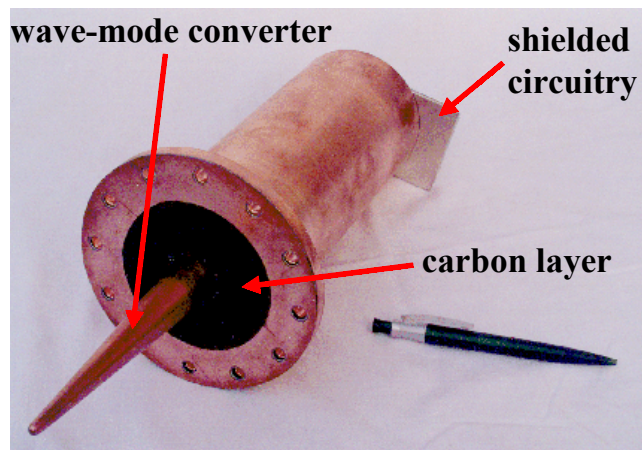

Fig. 9. Waveguide-fitted calorimetric sensor.

The sensor circuitry (Fig. 10) works as an integrator. The diagonal voltage on the thermistor bridge is proportional to the carbon layer temperature. The voltage from bridge is fed to the differential amplifier, which helps to suppress the influence of thermal fluctuations with the help of vicinity temperature sensor. The output signal is integrated by an amplifier with automatic offset compensation. The integral of the calorimeter voltage is proportional to absorbed pulse energy, as shown in Fig.11.

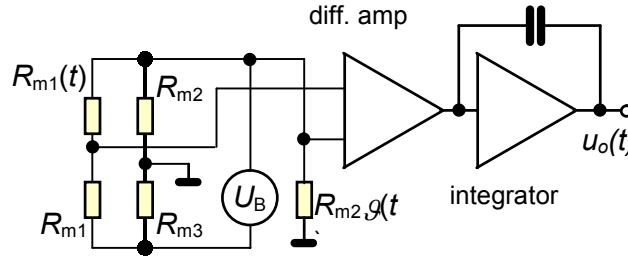

Fig. 10. Principle scheme of the sensor circuitry.

3.2 Free-space combined calorimetric sensor

For the measurement of free-space vircator EMP, the new combined calorimetric sensor was built. The sensor operation is based on the version I and IV of the calorimetric methods in Fig. 5. The first part (version I) serves as the sensor of instantaneous power and the second part (version IV) serves as the sensor of pulse energy.

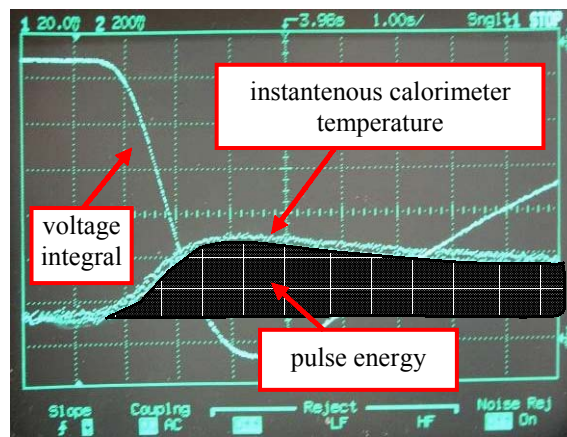

Fig. 11. The output voltage of the calorimeter and its integral.

The realization of the combined sensor is shown in Fig. 12. Both parts are equipped with Horn antennas to ensure the matching of the free-space EMG wave to the sensor input. The parameters of the antenna obtained by the help of numerical simulation are following [9]: gain $G = 19$ dB, 3dB beam angle $\theta_{3dB} = 21^\circ$, 6dB beam angle $\theta_{6dB} = 30^\circ$, front-to-back ratio $FBR = 69,4$. The radiation pattern of the Horn-type antenna in dB is shown in Fig. 13.



Fig. 12. Realization of optimized combined calorimetric sensor.

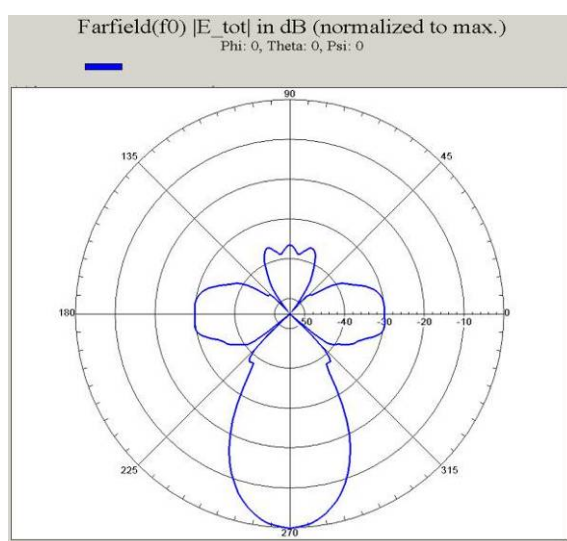

Fig. 13. Radiation pattern of Horn-type antenna in dB.

The sensor was calibrated with an RF generator in a semi-anechoic room in VTUPV Vyškov, Fig. 14. The calibration was performed for microwave pulses with defined duration and power level, with the frequencies $f=3, 4, 5,$ and 6 GHz. The power level and pulse duration relation were set for emitted energy $F_{\text{test}} \in \langle 0,1; 10 \rangle$ J.

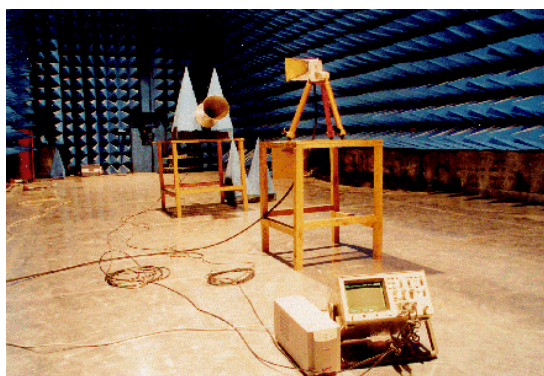

Fig. 14. Calibration of the calorimetric sensor.

Due to safety requirements, the connection between the sensor and the measuring device was ensured by means of coaxial cable of the minimum length $l_{\min} = 10$ m.

The combined calorimetric sensor was used for the measurement of vircator-emitted EMP. The supply of the vircator was provided by pulse high-voltage source powered by Marx bank. When the vircator is in the operational mode, hard RTG emission is generated in addition to the microwave emission. The energy of the electron beam is $W_b = 1$ MeV. Therefore, safety requirements equal to those mentioned above have to be considered.

The waveform of the measured small microwave power is in Fig. 15. The peak value of the vircator-emitted EMP reached $P_{\max} = 50$ kW in this experiment. However, vircator is able to emit EMP with peak value of hundreds of MW when supplied with proper pulsed power generators.

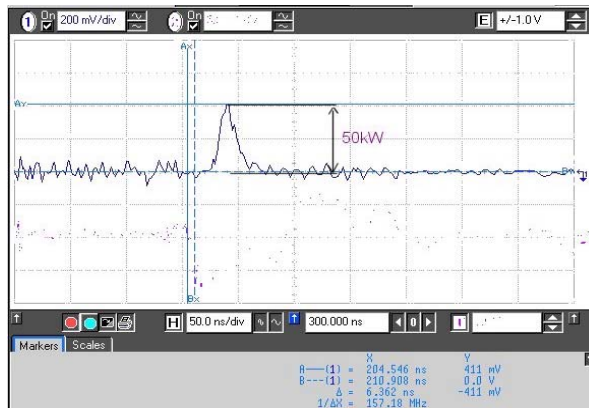

Fig. 15. Measured waveform of small microwave power, $P_{\max} = 50$ kW.

4. Design of the Magneto-optic Method

The magneto-optic (MO) method is proposed for further experiments. The magneto-optic method allows ultra-short pulses waveform measurement because of its high bandwidth. The polarization rotation of light passing the MO sensor is affected by the magnetic part of EM pulse. The rotation is due to the magnetic field and properties of the sensor material (Verdet constant). For the measurement the MO garnet, glass or thin film may be used [10].

The absolute measurement method utilizing the MO glass element was experimentally realized with low frequency magnetic field. Laser beam with linear polarization passes the MO glass placed in Helmholtz coil. The laser beam is subsequently fed through an analyzer and the polarization rotation is converted to intensity modulation. The intensity of light is sensed by a photodiode. The magneto-optic glass FR-5 by Hoya Optics was used in this experiment. Fig. 16. shows the MO element in the holder.



Fig. 16. *Magneto-optic element (FR-5) in the holder.*

Next, the differential method was experimentally realized [11]. The differential method utilizes Wollaston prism and offers better sensitivity. It is proposed for the next pulse current sensor development. The experiment for the measurement of high frequency magnetic field is in development – Fig. 17.



Fig. 17. *Experimental setup for high frequency magnetic field measurement.*

The sensitivity of the sensor and its bandwidth are contradictory properties. Because of the high power level of EM pulse the sensitivity of the sensor is not a critical requirement. The bandwidth of the sensor has to be appropriate to the measured signal characteristic – it has to be able to detect transients with duration 1 ns. The corresponding bandwidth for this requirement reaches the value of 350 MHz.

5. Conclusions

The overview of several methods suitable for the measurement of short solitary pulses with high power level was given. The characteristics of the designed method were discussed. Some methods were experimentally tested and evaluated. A combined calorimetric sensor for free-space measurement was built and the functionality of the calorimetric sensor was proved by real measurement of vircator-emitted EMP.

Acknowledgements

The paper was prepared within the framework of the research plan No. MSM 0021630513 of the Ministry of Education, Youth and Sports of the Czech Republic.

References

- [1]. P. Fiala, *Non-conventional sources of electrical energy*. Brno University of Technology, 2003.
- [2]. P. Fiala, P. Drexler, J. Rychnovský, *Pulsed power generator with output power up to 20GW, research report*. HS Prototypa a.s., 18580001.
- [3]. R. J.Barker, E. Schamiloglu, *High-Power Microwave Sources and Technologies*. IEEE Press, 2001.
- [4]. P. Drexler, P. Kaláb, P. Fiala, Inductance-free high voltage divider for extreme conditions. In *Proceeding of 16th International Conference Dielectric and Insulating Systems in Electrical Engineering 2006*, Casta-Pila, Slovakia, 12-14 September 2006, pp. 168.
- [5]. J. A. Riordan, F. G. Sun, Z.G. Lu, X. C. Zhang. Free-space transient magneto-optic sampling, *Applied Physics Letters* 71, 1997. p. 1452-1454.
- [6]. M. Kasal, *Multinuclear measuring channel of NMR spectrometer*. Brno University of Technology, 1984.
- [7]. M. Pfeffer, M. Kasal. Automatic impulse reflectometer, *Sdělovací technika* 10/11, 1986.
- [8]. P. Šunka, Verbal information. IPP CAS, Czech Republic, Praha, 2003.
- [9]. L. Palíšek, *The alternative to anti-infantry mines, research report*. VOP26 Šternberk, VTUPV Vyškov, Czech Republic 2005.
- [10]. A. E. Craig, K. Chang, *Optical modulation: Magneto-optical device, Handbook of Optical Components and Engineering*. John Wiley & Sons, New Jersey, 2003.
- [11]. P. Drexler, *Methods for the measurement of ultra short electromagnetic pulses, Treatise on the Ph.D. thesis*. Brno University of Technology, 2006.



