

Lead-acid Battery Intelligent Management System Based on TMS320F2812

^{1,3} Zhang Haoming, ² Peh Lian Soon, ³ Wang Yinghai

¹ Department of Electrical and Information Engineering, Tongling University,
Anhui Province, 214000, China

² Shining Sunshines Global PTE LTD, Singapore

³ School of Electrical and Information Engineering, SIPIVT, Jiangsu Province, 215123, China

¹ Tel.: 13013801792

¹ E-mail: zhm20060616@163.com

Received: 11 June 2014 / Accepted: 29 August 2014 / Published: 30 September 2014

Abstract: Because of small volume, high energy density, relatively high single cell voltage, low self-discharging rate, small resistance, Lead-acid battery has been widely used in hybrid electric vehicle systems, but difference between every unit, defects of sensitive to temperature, sensitive to voltage and current has limited its use. Intelligent management system of lead-acid battery based on TMS320F2812 was designed to solve these problems. Experiment results prove the effectiveness of the design. *Copyright © 2014 IFSA Publishing, S. L.*

Keywords: Hybrid electric vehicle, Lead-acid battery, Intelligent management system.

1. Introduction

With the development of auto industry, excessive energy consumption and serious pollution of the environment, forces people to begin to consider the development of a new generation of energy-saving and environment-friendly vehicles. The development of HEV (hybrid electric vehicle) is one of the best solutions to solve these problems [1-5]. When the vehicle is in low speed area, to improve the efficiency of the engine, generally shut down the engine, using high performance battery provides power to meet the normal running of the vehicle, batteries used in HEV system are: lead-acid battery, Ni-MH battery, Ni-Cd battery and lithium-ion battery. Compared with other battery, voltage of lead-acid battery is relatively high (2.0 V), slightly lower than the lithium-ion battery, but compared with the lithium-ion battery, its price is quite low; Lead-acid battery can be of various sizes and various shapes

which can be made from a few Ah to thousands of Ah, and its SOC (state of charge) is easy to identify. These features make lead-acid battery is widely used in hybrid vehicles.

Although lead-acid battery used in a hybrid energy system has a lot of advantages, there are also some shortcomings, such as,

1) Each single cell has its own capacity, even the same batch batteries, the capacities are not the same.

2) In the process of charging and discharging, every battery can fail to work, if the phenomenon can not be found in time, damage of the energy system will be caused.

3) Battery in this system not only under the influence of the outside temperature, but also under the influence of temperature caused by changing and discharging, which increases the battery inside pressure, at last even explode.

4) In the charging process, increasing the charging current to reduce charging period, but the

3.2. Over/under Voltage Protection Circuit

Over/under voltage protection circuit as shown in Fig. 3: when battery is in charging, voltage sampling circuit detects each cell of the energy system, when any single voltage exceeds the upper limit voltage 2.4 V, the DSP controller will send over-voltage protection signal to charging MOSFET, quickly pull the gate signal low and fast shut down the charging channel; when the battery is in discharging, voltage sampling circuit begins to work, when any cell's voltage below the lower limit voltage 1.9 V, the DSP controller sends under-voltage protection signal to the discharging MOSFET, quickly pull the control signal low and fast shut down the discharging channel.

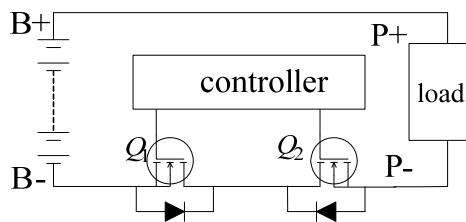

Fig. 3. Over/under voltage protection circuit.

3.3. Temperature Protection Circuit

When the lead-acid battery discharge with a high current, a sharp rise of the surrounding temperature will be caused, which has a negative influence on MOSFET and lead-acid battery itself. In order to protect the discharging circuit and the battery, temperature switch is added in the system, the switch is put on the surface of MOSFET. When the system is over temperature, DSP controller forces discharging MOSFET gate signal to low, and quickly turn off the discharging channel.

3.4. Battery Equalization Circuit

Battery equalization circuit keeps each cell of the series battery in the same voltage, which can make the system maintain a steady state in a certain period, at present mainly judges the degree of equalization according to the terminal voltage of battery. Most equalization circuit are energy consumption types, the basic idea is to consume the excess energy from the highest voltage battery by a resistor, which causes a great deal waste of energy. To save energy, this paper proposes an energy feedback equalization circuit based on super capacitor, as shown in Fig. 4.

Electronic controller is connected to the corresponding switch so that the capacitor C can charge or be discharged. Because of the difference in voltage, and the power is transferred from B1 to the

B2 or from B2 to B1. In the same way, energy is transferred from B1, B2.....to Bn. High power cell will charge the capacitor C, and low power cell will be charged by the capacitor C. Using this method, a higher power cell transfer its power to a lower power cell. This method only needs a fixed switching sequence, to connect or disconnect the corresponding switch.

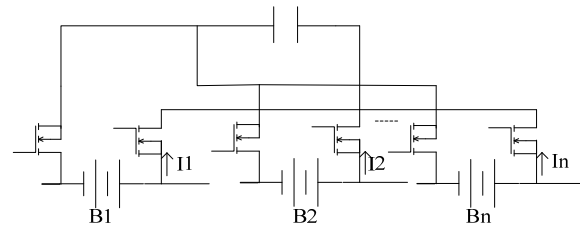

Fig. 4. Energy feedback equalization circuit principle.

Energy feedback type equalization circuit just by using a large capacitor, the energy consumption of the capacitor is very small, just transfers energy from one cell to another, which has a good application in battery charging process.

3.5. Self-lock Circuit

Because all the cells at low voltage can rebound its voltage, this phenomenon makes the circuit turn off and turn on back and forth which causes many energy losses, especially for hard switching circuit, it is easy to cause the battery discharge with large current, which harms every cell of the system, ultimately affect the entire working cycle of the system, the low limit voltage self-lock circuit based on 9015 is designed as shown in Fig. 5.

When the voltage detection circuit finds the energy system is in low state, the DSP controller sends an alarm signal to the low limit self-lock circuit, then the discharging channel is closed.

3.6. Power Display Circuit Principle

Power display circuit principle based on TMS320F2812 is shown in Fig. 6: in this system, voltage sampling circuit is connected to TMS320F2812, after sampling date is transferred to AD conversion circuit and compared with set value, then the DSP sets IO port state, the number of light emitting diode will be changed. When the power is in the highest state, LEDs are all on light; when the battery is in low voltage state, LEDs are all extinguished, at the same time, request of charging is set to DSP, DSP makes the charging channel on, then the system can charge the lead-acid battery.

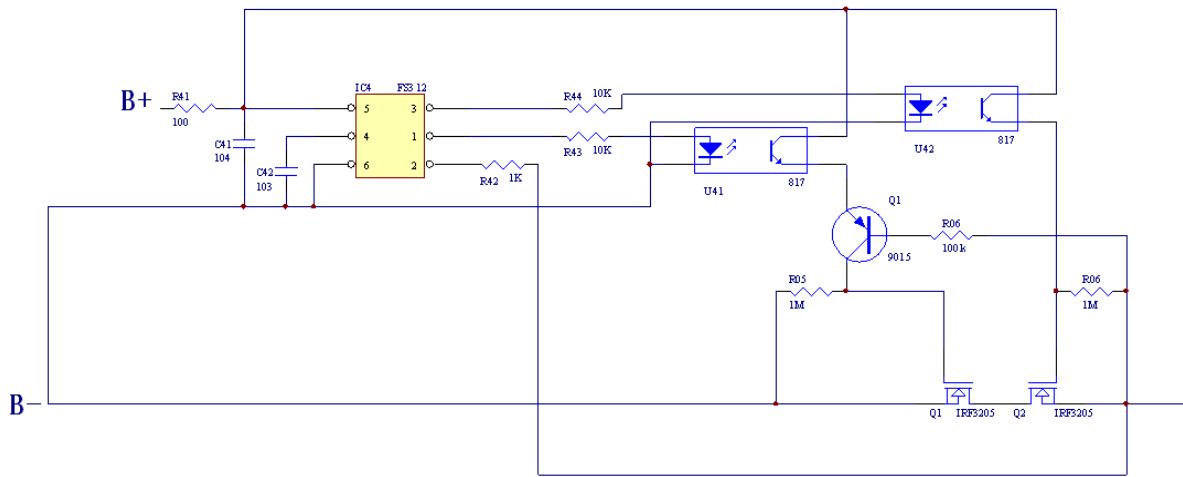

Fig. 5. The self-lock circuit principle.

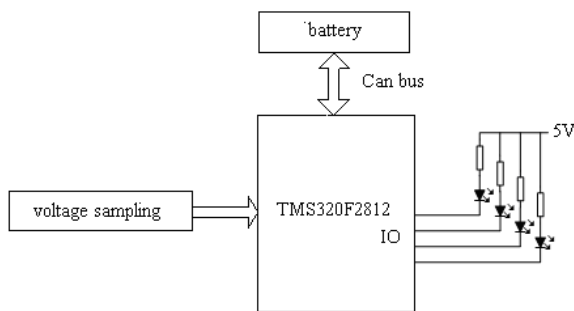

Fig. 6. Power display circuit principle.

algorithm involves in this system can have a higher accuracy. TMS320F2812 has additional advantages compared with other common DSP, it uses high performance static CMOS technology, supply voltage is reduced from 5 V to 3.3 V, which can reduce power consumption. And improve the instruction execution speed to 40MIPS, making it possible to improve the performance of the system by using the advanced control algorithm. Compared with TMS320LF2407A, the processing speed of TMS320F2812 is 5 times of TMS320LF2407A, the AD conversion accuracy is 12 bit (TMS320LF2407 the 10 bit AD), conversion accuracy can be higher. In the control system, using TMS320F2812 as the control processor has its main advantages: high precision, high reliability, high integration and high flexibility, suitable for HEV intelligent management system.

4. Software

At present, high speed, high performance DSP has gradually become one of the main control chip is widely used in control system. TMS320F2812 is an efficient 32 bit fixed-point DSP chip based on C and C++ language, attached math library can achieve floating-point operation, which makes PWM

Lead-acid battery intelligent management system is designed in this paper, taking TMS320F2812 as the core, intelligent system software flow chart is shown in Fig. 7.

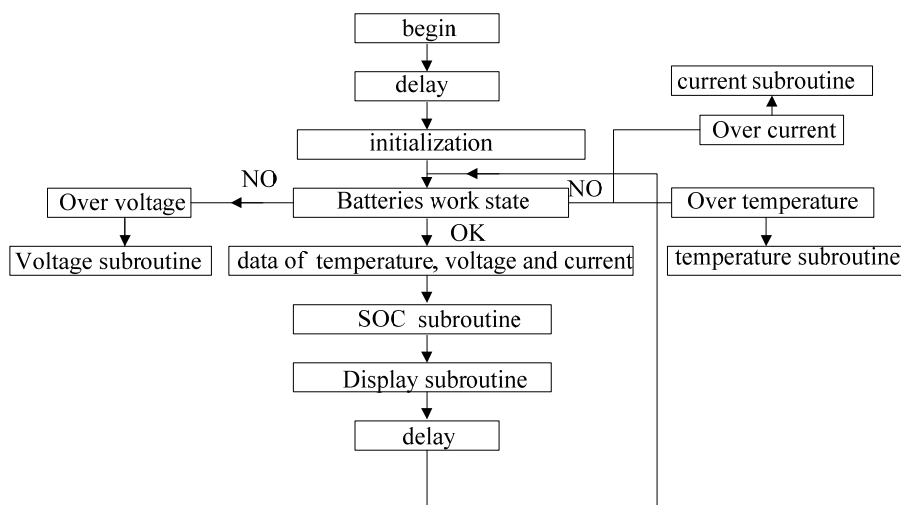

Fig. 7. Flow chart of intelligent system software.

5. Experiment

The experimental platform for the energy system as shown in Fig. 8.



Fig. 8. The test platform of lead-acid batteries intelligent management system.

Fig. 9 shows current waveform of the charging circuit in the constant current charging stage. As can be seen that output current ripple is very small.

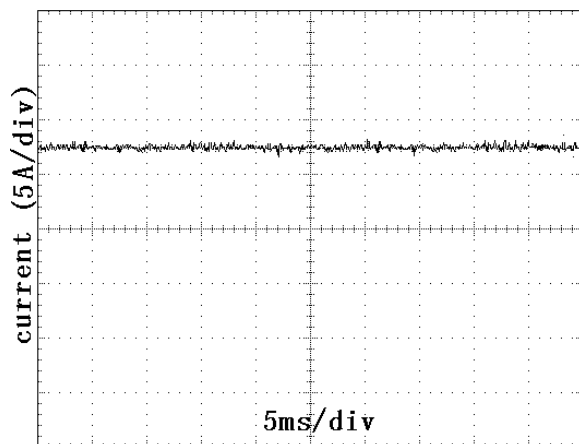

Fig. 9. The charging current waveform.

Artificially increase the surface temperature of charge MOSFET, the test results is shown in Fig. 10. From the result of the experiment can be seen, when the temperature exceeds 110, DSP immediately shuts down the MOSFET. Then cold air is added to the system to decrease the temperature, so MOSFET temperature decreased rapidly, even the spot temperature is decreased to about 50, the driving signal is also at a low level, MOSFET can not be opened, which is effective to protect the system.

Increase the discharging current, waveforms of the discharging current and MOSFET drive signal as shown in Fig. 11.

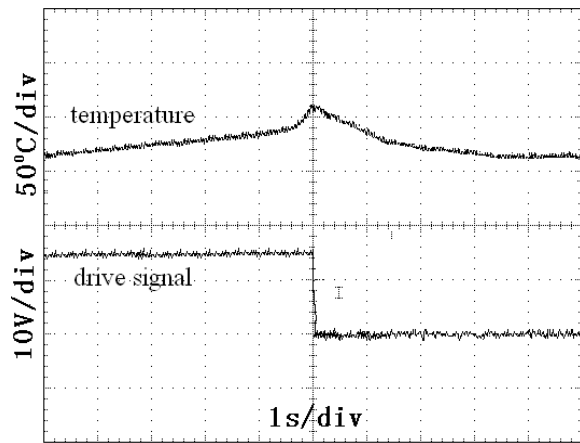

Fig. 10. Temperature test waveform.

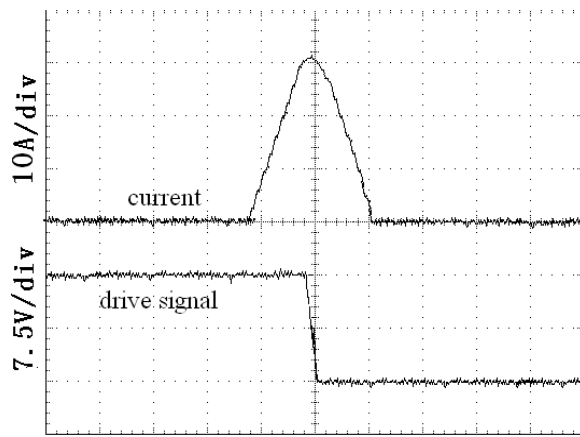

Fig. 11. Over charging experiment.

As can be seen from figure 11, when the discharging current increases over the limit of protection, after a delay of about 100ms, the MOSFET drive signal is changed from high level to low level, and the controller quickly turns off the discharging channel, which effectively protects the battery to avoid depth discharging.

In the low voltage stage, self-lock circuit is tested, results as shown in Fig. 12: when the battery voltage drops to a lower voltage, self-lock circuit starts to work, immediately turn off the discharging circuit, then the voltage of the battery begin to rise, but the discharging MOSFET control signal also keeps in low level, which effectively solves the problem of battery excessive discharging in low voltage.

After a long time charging or discharging, collects relevant data: voltage of every cell of the energy system with protection circuit and without protection circuit are shown in Fig. 13.

As can be seen from Fig. 13, the upper limit voltages of the batteries with equalization circuit are kept in the equilibrium point (about 2.22 V), which is effective to protect the consistency of all batteries; Voltage of batteries without equalization circuit appears to be no rules can use, which harms the energy system greatly.

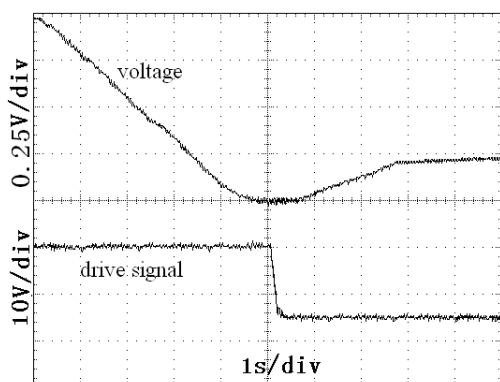
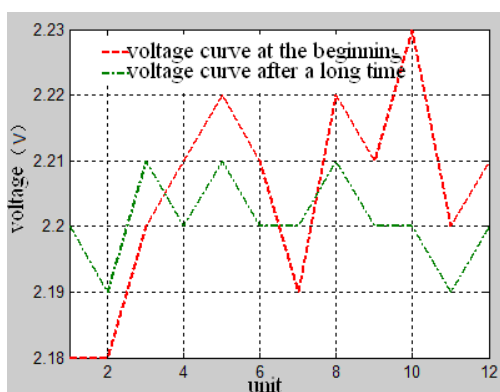
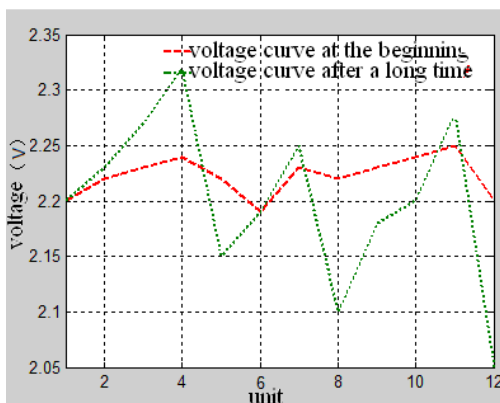

Fig. 12. Self-lock circuit test waveforms.



(a)



(b)

Fig. 13. Cell voltage of energy system.

6. Conclusion

In view of traditional protection circuit deflection, intelligent management system based on TMS320F2812 of lead-acid battery is discussed and designed, experiment results show that the intelligent management system can effectively monitor and protect every cell of the energy system.

Acknowledgment

It is a project supported by basic research programs of Suzhou science and Technology Department - industrial application part (SYG201327) and 2012 Innovation Project of Jiangsu Province.

References

- [1]. Hassan Moghbelli, Abolfazl Halvaei Niasar, Reza Langari, New generation of passenger vehicles: FCV or HEV? in *Proceedings of the IEEE International Conference on Industrial Technology (ICIT'06)*, Mumbai, 15-17 December 2006, pp. 452-459.
- [2]. Yimin Gan, Khwaja M. Rahman, and Mehrdad Ehsani, The energy flow management and battery energy capacity determination for the drivetrain of electrically peaking hybrid vehicle, *Society of Automotive Engineers (SAE) Journal*, 1997, Paper No. 972647.
- [3]. M. Mastragostino, F. Soavi, Strategies for high-performance supercapacitors for HEV, *Journal of Power Sources*, Vol. 174, No. 1, 2007, pp. 89-93.
- [4]. Valerie Johnson, Kieth Wipke, David Rausen, HEV control strategy for real-time optimization of fuel economy and emissions, *Society of Automotive Engineers (SAE)*, 2000, Technical Paper 2000-01-1543.
- [5]. N. J. Schouten, M. A. Salman, N. A. Kheir, Energy management strategies for parallel hybrid vehicles using fuzzy logic, in *Proceedings of the First IFAC-Conference on Mechatronic Systems*, Darmstadt, Germany, 2000, Vol. 9, pp. 18-20.
- [6]. L. Gopikanth, and S. Sathyanarana, Impedance parameters and the state-of-charge. II. Lead-acid battery, *Journal of Applied Electro-Chemistry*, Vol. 9, Vol. 3, 1979, pp. 369-379.
- [7]. P. Mauracher, E. Karden, Dynamic modeling of lead/acid batteries using impedance spectroscopy for parameter identification, *Journal of Power Sources*, Vol. 67, Issue 1-2, 1998, pp. 69-84.
- [8]. Z. M. Salameh, M. A. Casacca, and W. A. Lynch, A mathematical model for lead-acid batteries, *IEEE Transactions on Energy Conversion*, Vol. 7, Issue 1, 1992, pp. 93-98.
- [9]. R. Giglioli, P. Pelacchi, V. Scarioni, A. Buonarota, and P. Menga, Battery model of charge and discharge processes for optimum design and management of electrical storage systems, in *Proceedings of the 33rd International Power Source Symposium*, June 1988, pp. 1-6.
- [10]. H. P. Schoner, Electrical behavior of lead/acid batteries during charge, overcharge, and open Circuit in *Proceedings of the 9th Electric Vehicle Symposium (EVS-9)*, 1988, paper #0063.
- [11]. S. Sato, and A. Kawamura, A new estimation method of state of charge using terminal voltage and internal resistance for lead acid battery, in *Proceedings of the Power Conversion Conference (PCC'02)*, Osaka 2002, Vol. 2, pp. 565-570.