

Fault Diagnosis Based on Bayesian Petri Nets

Yonghui Yi

XJ Electric Company Limited, Xuchang 461000, China

Tel.: +86-0374-3211919, fax: +86-0374-3216619

E-mail: yih6006@163.com

Received: 7 May 2014 /Accepted: 29 August 2014 /Published: 30 September 2014

Abstract: This paper provides a kind of Bayesian Petri net model and presents a fault diagnosis method for power grid based on this model. Firstly, the BPN models for each component are established in power cut area separately, according to the fault spread directions. Secondly, the failed component is determined by the application of Petri net reasoning and Bayesian probability calculation. At last, the result is given by fusing all parties' results using mean method. Diagnosis analysis showed that this method had better fault tolerance under the condition of incomplete information and had better adaptability after the change of network topology structure. In the BPN reasoning, calculating the fault probability of component is based on the prior probability from statistics, so the subjectivity of setting related parameters can be avoided.
Copyright © 2014 IFSA Publishing, S. L.

Keywords: Bayesian Petri nets, Fault diagnosis, Power system, Fault tolerance.

1. Introduction

With the expansion of the scale of the power systems and the improvement of the level of automation, the complexity of system operation and losses caused by the problems of the power system increase greatly comparing with the previous. It's significant to find out the problems of the systems promptly and accurately for ensuring the power systems running in a safe and stable condition. At present, the more and more technology and methods of the computational intelligence and knowledge engineering are used in the area of fault diagnosis by the researchers [1-3], for example, expert system, artificial neural network, rough set theory, fuzzy set theory, Bayesian network, genetic algorithm and so on. These methods have their own characteristics and have been used to a certain extent, but in some cases they also expose some shortcomings [2]. For example, expert system's rule base is difficult to establish; artificial neural network needs much large representative samples for learning before being

used; when the method of rough set theory is in use, the decision table is very huge, even sometimes, the problems of the combinatorial explosion may come up; the part of the fuzzy set theory concerning about obtaining the membership function and the method of the fuzzy models for complex systems is not complete; Bayesian network's training is complex and it needs the information of the priori probability; it's a NP hard problem to analysis the complex problems and the large scale system; to the genetic algorithm, it has difficulty in setting up the reasonable fitness function and making the right parameter selection.

Some researchers combine a variety of methods, in this way they can avoid the shortage of using a method only. The quantum theory is brought in the training process of the neural network; it can improve the properties [3]. A fault diagnosis method based on rough set theory and Bayesian classifier is proposed to increase the fault tolerance ability with incomplete information [4]. Petri net is a kind of mathematical tools for analyzing the behavior of the discrete event

dynamic system (DEDS). It has not only a strict mathematical description but also has an intuitive graphical expression [5]. Power system is a typical discrete event dynamic system, so it is reasonable to use the Petri nets to model the fault diagnosis of the power systems. Petri net is applied in power system, including fault diagnosis, fault recovery, network topology analysis [6]. In [7] the authors give the backward reasoning based on Petri net. K. L. Lo and H. S. Ng set up Petri net model and algorithm for fault diagnosis based on coding, and they compare with other methods of fault diagnosis in power systems [8]. According to the time sequence of the protection action, the fault diagnosis model of Petri net is established based on the distribution protective circuit breakers [9].

The main feature of the Petri net method for fault diagnosis in the power systems is that it can make qualitative and quantitative analysis for the evolution process whether these fault occur concurrently or orderly or circularly. But this kind of method has obvious deficiency. In the first, it needs enough knowledge to establish a complete Petri net model, but it will be easy to produce the problem of the state space explosion if the net has too many nodes. Secondly, it is difficult to adapt to the changes of the power system topology. At last, the fault tolerance ability of the model is poor, for example, it is difficult to identify the false alarm information. Therefore, when the scale of the net is large or when complex problems of the system occur, fault diagnosis is difficult based on the Petri net model.

According to the complex power grid, a power grid fault diagnosis method based on directional weighted fuzzy Petri net (WFPN) is proposed [10]. And the elements are modeled on every fault spread direction to insure the universality in the condition of topology changes and the fault tolerance of the algorithm with incomplete information. This method can reduce calculation cost and obtain the rank of suspicious faulty components with incomplete information. However, there is a big subjective in setting the threshold and the weights of WFPN, it is bad adaptable to different samples.

2. Bayesian Petri Nets

2.1. Bayesian Probability Reasoning

Bayesian network is an information presentation framework which combines the causal knowledge and the probabilistic knowledge [11]. Bayesian network $B(G, P)$ consists of the directed acyclic graph G which has n nodes and the conditional probability table P which is interrelated with every node.

The node-set of G is described by the variables in the domain $U = \{x_1, x_2, \dots, x_n\}$, and the directed arcs mean the relationship between variables. The parent node of the node x_i is described by $parents(x_i)$.

The relationship between variables is showed by the conditional probability $p(x_i | parents(x_i))$ between the node x_i and the parent node $parents(x_i)$. The joint probability distribution of the variables is showed by (1) [11].

$$p(U) = p(x_1, x_2, \dots, x_n) = \prod_{i=1}^n p(x_i | parents(x_i)), \quad (1)$$

The random variable x_i has m basic events $\{x_{i1}, x_{i2}, \dots, x_{im}\}$. If the observed result is $V = \{x_1, \dots, x_{i-1}, x_{i+1}, \dots, x_n\}$, the conditional probability is showed by (2) [11].

$$p(x_i = x_{ij} | V) = \frac{p(x_i = x_{ij}, V)}{\sum_{k=1}^m p(x_i = x_{ik}, V)}, \quad (2)$$

The posterior probability of $x_i = x_{ij}$ can be calculated by the formula (1) and (2) based on the backward reasoning of Bayesian network [11].

$$p(x_i = x_{ij} | x_1, \dots, x_{i-1}, x_{i+1}, \dots, x_n) = \frac{p(x_i = x_{ij}) \prod_{a \neq i} p(x_a | parents(x_a))}{\sum_{k=1}^m [p(x_i = x_{ik}) \prod_{a \neq i} p(x_a | parents(x_a))]}, \quad (3)$$

If the parent node-set of the x_a meets $parents(x_a) = \emptyset$ in (3), we can conclude that $p(x_a | parents(x_a)) = p(x_a)$.

The Bayesian network model can indicate the joint probability of the variables set, and the causal relation of the parent node and the child node can reflect accurately the dependency between them. So we can obtain the effective causal reasoning and diagnosis reasoning by using the Bayesian network.

But there are two main shortcomings when the Bayesian inference is applied to fault diagnosis: 1) when analyzing the complex fault and the large-scale system, we need more complex training in the network, and the calculation of the conditional probability table P is proved a NP-complete problem [1]; 2) the method of Bayesian reasoning need to rebuild the network structure and recalculate the conditional probability distribution, when the configuration of the component and the protection devices change.

2.2. Definitions of Bayesian Petri Nets

This paper defines the Bayesian Petri nets (BPN) taking Bayesian reasoning and Petri nets into consideration based on [10, 11].

Definition 1: Bayesian Petri nets (BPN) structure is a ten- tuple $\Sigma_{BPN} = \{S, T, F, I, U, R, SU, PR, B, M_0\}$; where:

$S = \{s_1, s_2, \dots, s_n\}$ is the finite set of places;
 $T = \{T_N, T_B\}$ is the finite set of transitions,

$T_N = \{t_{N1}, t_{N2}, \dots, t_{Nm}\}$ is the finite set of general transitions, $T_B = \{t_{B1}, t_{B2}, \dots, t_{Bk}\}$ is the finite set of Bayesian transitions; $F \subset (S \times T) \cup (T \times S)$ is the finite set of arcs; $I \subset S \times T$ is the finite set of inhibitor arcs, $I \cap F = \emptyset$; $U = \{x_1, x_2, \dots, x_n\}$ are the finite variable set, the value of the variable x_i is $\{0,1\}$; $R \subset U$, $R(x_i)$ is the reason variables set of x_i based on causal relationship; $SU: S \rightarrow U$ is the mapping from S to U; $PR: U \rightarrow [0,1]$, $PR(x_i)$ is the priori probability of x_i ; $B: T_B \rightarrow [0,1]^j$, $B(t_{Bi})$ is probability distribution vector of t_{Bi} under the condition of $\bullet t_{Bi}$ (In this paper, we use the $\bullet t$ indicate the pre-places of t , and the $t \bullet$ indicate the post-places of t).

$$B(t_{Bi}) = [b(s_1), b(s_2), \dots, b(s_j)], \quad (4)$$

where $b(s_i) = p(s_i | \bullet t_{Bi}), i=1,2,\dots,j$; M_0 is the initial marking of Σ_{BPN} .

Definition 2: Marking sets M of BPN

The marking M_i is the description of the system dynamic behavior and the set of all marking of the system can be marked as M. The marking is described by $M_i = \{(s, \pi(s))\}$, in which $\pi(s) \in \{0,1\}$ shows that whether the token s of the place exists or not. And 1 indicates the token s exists. The component of $M_i, M_i(s) = (s, \pi(s))$ is value of the posterior probability of the physical meaning which the places indicates. If M_k turns up by the fire of M_j straightway, which marked as $M_j[t > M_k]$.

Definition 3: Fire rules of Σ_{BPN}

1) When $t_B \in T_B$, if $\forall s \in \bullet t_B: (s, t_B) \in I \rightarrow \pi(s) = 0$ and $\exists s \in \bullet t_B: (s, t_B) \in F \rightarrow \pi(s) = 1$, the transition t_B is enabled, marked as $M_i[t_B >]$.

2) When $t_N \in T_N$, if $\forall s \in \bullet t_N: ((s, t_N) \in I \rightarrow \pi(s) = 0) \wedge ((s, t_N) \in F \rightarrow \pi(s) = 1)$, the transition t_N is enabled, marked as $M_i[t_N >]$.

3) When the marking is M_i , the new making M_{i+1} turns up by the fire of the transition. We can mark it as $M_i[t > M_{i+1}]$, and if $\forall s \in t \bullet: \pi(s) = 1$, then

$$M_{i+1}(s) = \begin{cases} \max(M_i(s), b(s)) & \text{if } s \in T_B \wedge s \in t \bullet \\ 1 & \text{if } t \in T_N \wedge s \in t \bullet \end{cases}, \quad (5)$$

3. Fault Analysis and Diagnosis Based on BPN

3.1. Relay Protection Analysis of Fault Component

Relay protection of the power system usually includes the main protection, the nearly back-up protection and the remote back-up protection [12].

For example, The Layout diagram in figure 1 consists of three components: 1 bus (B1) and 2 lines (L1, L2); 13 protection: main protection of bus (B1m), main protection of line (L1Sm, L2Sm, L1Rm, L2Rm), nearly back-up protection of line (L1Sp, L2Sp, L1Rp, L2Rp) and remote back-up protection of line (L1Ss, L2Ss, L1Rs, L2Rs) and 5 breakers (CB1 ~ CB5).

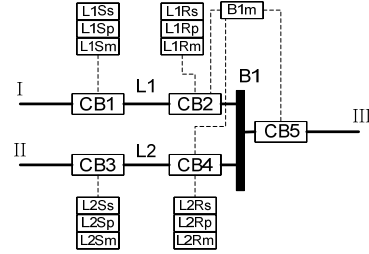

Fig. 1. Fault components and its protection device.

If the information received from the monitoring center is the sequential action of B1m-L1Ss-L2Ss and the open of breakers CB1-CB3-CB5. According to the protection principle of the power system and the analysis of the three pathways in Fig. 1, we can obtain protection action sequence when the component fails, which is shown in Table 1.

Table 1. Protection action sequences.

	Protection action sequences caused by fault		
	Pathway I	Pathway II	Pathway III
B1	B1m→CB2 B1m→CB2→ L1Ss→CB1	B1m→CB4 B1m→CB4→L2S→C B3	B1m→CB5
L1	L1Sm→CB1 L1Sm→CB1→ L1Sp→CB1 L1Rm→CB2 L1Rm→CB2→ L1Rp→CB2	L1Rm→CB2→L1Rp →CB2→L2Ss→CB3	
L2	L2Sm→CB3 L2Sm→CB3→ L2Sp→CB3 L2Rm→CB4 L2Rm→CB4→ L2Rp→CB4	L2Rm→CB4→L2Rp →CB4→L1Ss→CB1	

3.2. Modeling of Bayesian Petri Nets

In order to reduce the complexity of the modeling and reasoning, first of all, we should construct Bayesian Petri nets models of action sequence of components on every direction. As shown in Fig. 2, we fusion all reasoning results of different directions. The domain U in the model is used to analyze the components and protection devices. $U = \{B1, L1, L2, B1m, L1Sm, L2Sm, L1Rm, L2Rm, L1Sp, L2Sp, L1Rp, L2Rp, L1Ss, L2Ss, L1Rs, L2Rs, CB1, CB2, CB3, CB4, CB5\}$.

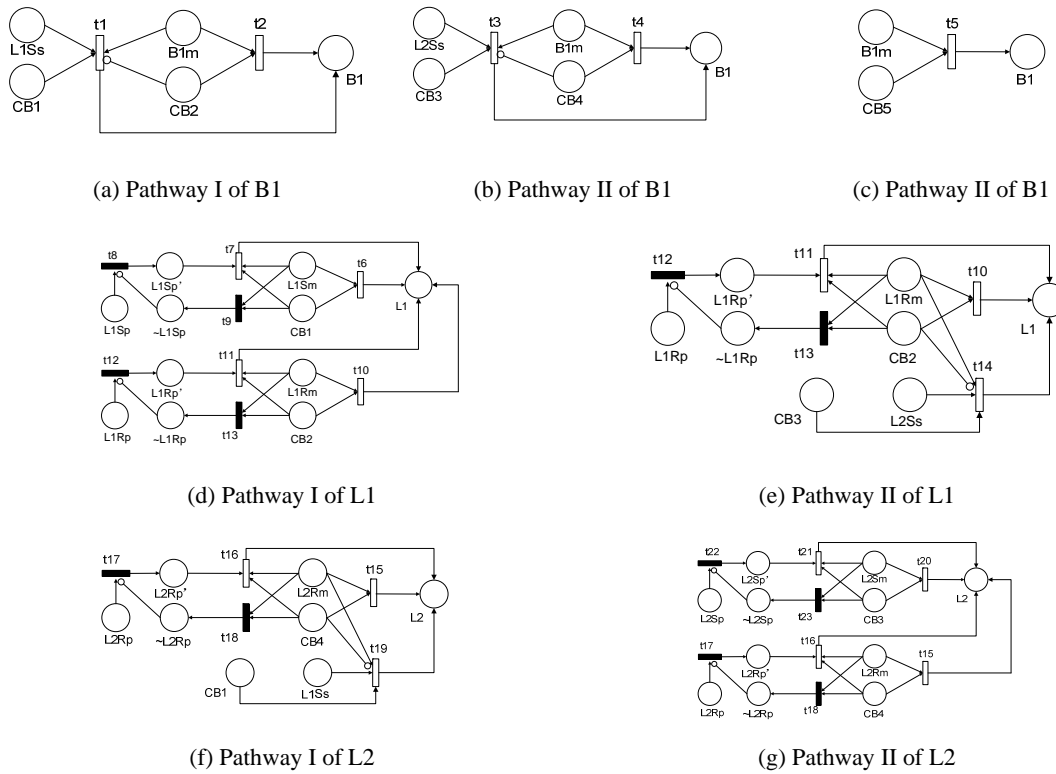

Fig. 2. BPN model in every direction.

In Fig. 2, the places are marked as \bigcirc , and the places with the same name of element in U represent the state of corresponding components and protection devices. The token in the places represent the posteriori probability of the state, and the place $\sim L1Sp$ means that the state of L1Sp is not arisen. The places $\sim L1Rp$, $\sim L2Sp$ and $\sim L2Rp$ indicates similar meaning of the place $\sim L1Sp$. The place L1Sp' means that the action of L1Sp occurs and abides by the relaying logic. The places L1Rp', L2Sp', L2Rp' indicates similar meaning of the place L1Sp'. The Bayesian transitions are marked as \square , which indicates the calculation of the neighbor places with the B function, as equation (4). The inhibitor arcs are marked as \bigcirc , which means the neighbor transition will not be fired by the pre-places with the token 1.

For example, the BPN model in Fig. 2(a) describes two cases: $B1m \rightarrow CB2$, $B1m \rightarrow CB2 \rightarrow L1Ss \rightarrow CB1$. It means that we can conclude B1 faulty when the monitoring center receives two signals (B1m, CB2) which indicate the action of B1m and the open of CB2. If the monitoring center receives three signals (B1m, L1Ss, CB1) which indicate CB2 refused to operate and CB1 made to be open by remote backup protection of L1Ss, we can still conclude B1 faulty.

3.3. The Parameter of Uncertain Information

In order to use the B functions and the PR functions of the BPN model to calculate and reason,

we need to obtain the prior probability of component fault and the conditional probability of the relay protection, and all these information reflect the uncertainties in process of fault. According to the data of [12], we can calculate the prior probability of component node fault. The prior probability of the line is 0.1629/hk (hundred kilometers); the bus, 0.0058/b (bar); the transformer, 0.0039/u (unit). The probabilities of the relay protection refused operation and faulty operation are followed: the faulty operation of the main protection of the line is 0.23 %/s (set), the refused operation, 0.07 %/s (set); the faulty operation of the main protection of the bus is 0.06 %/s (set), the refused operation, 3.08 %/s (set); the faulty operation of the main protection of the transformer is 0.14 %/s (set), the refused operation, 0.62 %/s (set); the faulty operation of the main protection of the breaker is 0.48 %/s (set), the refused operation, 0.83 %/s (set).

3.4. The Process of Fault Diagnosis

According to the BPN model in Fig. 2, we illustrate the process of fault diagnostic.

Case 1: The information got from the monitoring center is the action of B1m, L1Ss, L2Ss and the open of CB1, CB3, CB5.

The BPN model will be reasoned on every direction of the components. In the model the 1 indicates the action of the protection device, the open of the breaker and the fault state of the components; the 0 indicates the inaction of the protection device, the close of the breaker and the right state of the components.

The calculation process is shown in Table 2. The sequence of the transitions firing in the every BPN model is from up to down in the table. When the transition is firing, we can use equation (3) to calculate the probability value of the post- place by the B function and change the past probability. The initial marking M_0 of BPN will become the next marking, then the next marking will become the next of the next marking and the same process will go on. When there is no enabled transition, the making M is

the last marking. The value of $M(s)$ is the probability value of fault of the component which the place means. As the reasoning of BPN is done respectively on every direction of the components, we can get a set of diagnostic results for every component. Then we make the fusion of the diagnostic results with the mean value method in Table 2 and confirm the fault with the threshold 0.5 by the voting strategy. The final conclusion is that the bus B1 is faulty and the credibility is 0.9679.

Table 2. Fault probability in every direction.

Com- ponent	Path- way	Transition fire	Calculate of B function	Marking	Fault probability	Fusion value
B1	I	t2	$p(B1=1 B1m=1, CB2=0)$	$M0=\{(L1Ss,1),(CB1,1),(B1m,1),(CB2,0),(B1,0)\}$ $M1=\{(L1Ss,1),(CB1,1),(B1m,1),(CB2,0),0.9041\}$	0.9998	0.9679
		t1	$p(B1=1 B1m=1, CB2=0, L1Ss=1, CB1=1)$	$M2=\{(L1Ss,1),(CB1,1),(B1m,1),(CB2,0),0.9998\}$		
	II	t4	$p(B1=1 B1m=1, CB4=0)$	$M0=\{(L2Ss,1),(CB3,1),(B1m,1),(CB4,0),(B1,0)\}$ $M1=\{(L2Ss,1),(CB3,1),(B1m,1),(CB4,0),0.9041\}$	0.9998	
		t3	$p(B1=1 B1m=1, CB4=0, L2Ss=1, CB3=1)$	$M2=\{(L2Ss,1),(CB3,1),(B1m,1),(CB4,0),0.9998\}$		
	III	t5	$p(B1=1 B1m=1, CB5=1)$	$M0=\{(B1m,1),(CB5,1),(B1,0)\}$ $M1=\{(B1m,1),(CB5,1),0.9041\}$	0.9041	
L1	I	t6	$p(L1=1 L1Sm=0, CB1=1)$	$M0=\{(L1Sp,0),(L1Rp,0),(L1Sp',0),(\sim L1Sp,0),(L1Rp',0),(\sim L1Rp,0),(L1Sm,0),(CB1,1),(L1Rm,0),(CB2,0),(L1,0)\}$ $M1=\{(L1Sp,0),(L1Rp,0),(L1Sp',0),(\sim L1Sp,0),(L1Rp',0),(\sim L1Rp,0),(L1Sm,0),(CB1,1),(L1Rm,0),(CB2,0),0.0000\}$	0.0000	
		t7	$p(L1=1 L1Sm=0, CB1=1, L1Sp=0)$	$M1=\{(L1Sp,0),(L1Rp,0),(L1Sp',0),(\sim L1Sp,0),(L1Rp',0),(\sim L1Rp,0),(L1Sm,0),(CB1,1),(L1Rm,0),(CB2,0),0.0000\}$	0.0000	
	II	t14	$p(L1=1 L1Rm=0, CB2=0, L2Ss=1, CB3=1)$	$M0=\{(L1Rp,0),(L1Rp',0),(\sim L1Rp',0),(L1Rm,0),(CB2,0),(L2Ss,1),(CB3,1),(L1,0)\}$ $M1=\{(L1Rp,0),(L1Rp',0),(\sim L1Rp',0),(L1Rm,0),(CB2,0),(L2Ss,1),(CB3,1),0.0000\}$	0.0000	
L2	I	t19	$p(L2=1 L2Rm=0, CB4=0, L1Ss=1, CB1=1)$	$M0=\{(L2Rp,0),(L2Rp',0),(\sim L2Rp',0),(L2Rm,0),(CB4,0),(L1Ss,1),(CB1,1),(L2,0)\}$ $M1=\{(L2Rp,0),(L2Rp',0),(\sim L2Rp',0),(L2Rm,0),(CB4,0),(L1Ss,1),(CB1,1),0.0000\}$	0.0000	
	II	t20	$p(L2=1 L2Sm=0, CB3=1)$	$M0=\{(L2Sp,0),(L2Rp,0),(L2Sp',0),(\sim L2Sp,0),(L2Rp',0),(\sim L2Rp,0),(L2Sm,0),(CB3,1),(L2Rm,0),(CB4,0),(L2,0)\}$ $M1=\{(L2Sp,0),(L2Rp,0),(L2Sp',0),(\sim L2Sp,0),(L2Rp',0),(\sim L2Rp,0),(L2Sm,0),(CB3,1),(L2Rm,0),(CB4,0),0.0000\}$	0.0000	
		t21	$p(L2=1 L2Sm=0, CB3=1, L2Sp=0)$	$M1=\{(L2Sp,0),(L2Rp,0),(L2Sp',0),(\sim L2Sp,0),(L2Rp',0),(\sim L2Rp,0),(L2Sm,0),(CB3,1),(L2Rm,0),(CB4,0),0.0000\}$		

3.5. The Analysis of Fault Tolerance

Case 2: The monitoring center receives the following information: the action of B1m, L1Rm, L1Sp, L2Ss and the open of CB1, CB3, CB5.

The calculation process is showed in Table 3. As the length is limited, we only give the main

calculation steps. The final conclusion is: the bus B1 is faulty and the credibility is 0.9679; the line L1 is faulty and the credibility is 0.9941.

According to Table 1 and example 2, we know that the information received by the monitoring center may have deficiencies. In case 2, the monitoring center receives the information {B1m,

L1Rm, L1Sp, L2Ss, CB1, CB3, CB5}, and it is proved that the fault components are the bus B1 and the line L1. According to the analysis of Table 1, we know that the neighbor breakers of B1 will get the main protection signal from B1m and will be open when B1 is faulty. But the breakers CB2 and CB4 refuse to operate, then the remote backup protection L1Ss and L2Ss can make the breakers CB1 and CB3 to be open after receiving the protection signals. When L1 is faulty, the main line protection L1Sm and L1Rm will make the breakers on the both sides

to be open. But the breaker CB1 refuses to operation. The nearby backup protection L1Sp tries making the breaker CB1 to be open again. At last the breaker CB1 is open. In the above processes, the main line protection signal from L1Sm and the remote backup protection signal from L1Ss are not received by the monitoring center, but the missing information doesn't have significant influence to the results of fault diagnosis. Therefore, the BPN model provided in this paper has good universality and fault tolerance with incomplete information.

Table 3. Fault probability calculation.

Component	Pathway	Transition fire	Calculate of B function	Fault probability	Fusion value
B1		t2	$p(B1=1 B1m=1, CB2=0)$	0.9998	0.9679
		t1	$p(B1=1 B1m=1, CB2=0, L1Ss=0, CB1=1)$		
		t4	$p(B1=1 B1m=1, CB4=0)$	0.9998	
		t3	$p(B1=1 B1m=1, CB4=0, L2Ss=1, CB3=1)$		
		t5	$p(B1=1 B1m=1, CB5=1)$	0.9041	
L1	I	t6	$p(L1=1 L1Sm=0, CB1=1)$	0.9883	0.9941
		t8	—		
		t7	$p(L1=1 L1Sm=0, CB1=1, L1Sp=1)$		
		t10	$p(L1=1 L1Rm=1, CB2=0)$		
	II	t11	$p(L1=1 L1Rm=1, CB2=0, L1Rp=0)$	0.9999	
		t10	$p(L1=1 L1Rm=1, CB2=0)$		
		t14	$p(L1=1 L1Rm=1, CB2=0, L2Ss=1, CB3=1)$		
L2	I	t19	$p(L2=1 L2Rm=0, CB4=0, L1Ss=0, CB1=1)$	0.0000	0.0000
		t20	$p(L2=1 L2Sm=0, CB3=1)$	0.0000	
	II	t21	$p(L2=1 L2Sm=0, CB3=1, L2Sp=0)$		

3.6. Adaptability Analysis After Topology Change

The fault analysis based the BPN is modeled on every fault spread direction, so the model is only related to the protection and the breaker on this direction. For example, the line L3 is added to power system in Fig. 1, and the topology is changed as shown in Fig. 3(a). If we model this system and reason the fault based on Bayesian method, the Bayesian network for the whole system should be reconstructed and the conditional probability table of the nodes should be recalculated. Based on the proposed BPN model, the influence of the added L3 is just increasing a pathway IV. We only establish the corresponding subnet of the pathway. The existing structure and the results will not be affected.

Case 3: On the basis of case 1, L3 is added, the monitoring center receives the following information: the action of B1m, L1Ss, L2Ss, L3Ss and the open of CB1, CB3, CB5, CB7.

The diagnosis result of case 1 is the bus B1 faulty, the structure change for B1 in Fig. 3 (a) means adding a new pathway. Therefore, we can keep the model and the calculation results of the three existing pathways. The BPN model of pathway IV of the B1

is established as shown in Fig. 3(b). The initial marking M_0 is $\{(L3Ss,1), (CB7,1), (B1m,1), (CB4,0), (B1,0)\}$, after the transitions t24 and t25 fire, $M_2 = \{(L3Ss,1), (CB7,1), (B1m,1), (CB4,0), 0.9998\}$. After combining the results with the results of the original three pathways, we can get final conclusion: the bus B1 is faulty and the credibility is 0.9759.

The analysis and calculation process above shows that the method provided in this paper can keep its existing model and calculation results when the topology of the power system changes. It can only model the changed pathway, so we reduce the complexity of the modeling deeply. It shows that the BPN model can adapt to topology change better.

3.7. The Comparison of Methods

Compared with the reference [11], this method can reduce calculation cost and obtain the rank of suspicious faulty components with incomplete information. In addition, because the diagnostic process is modeled on a single component, and the failure probability of multiple fault spread direction is separately calculated, so the modeling complexity is lower than the analysis in reference [10].

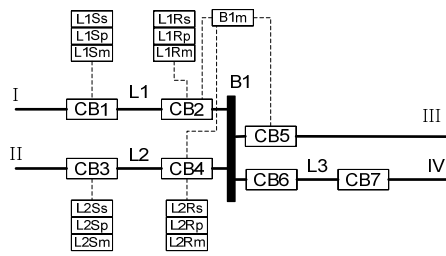

(a) Pathway IV increased

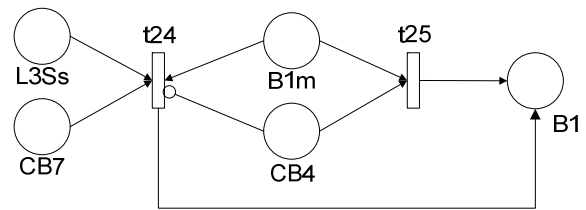

(b) BPN model of pathway IV

Fig. 3. The changed BPN model structure.

4. Conclusions

1) The Bayesian Petri nets combines the advantage of the Petri nets in the description and analysis of the discrete event dynamic system and the characteristic that Bayesian probability method is good at dealing with uncertain knowledge expression and reasoning. Based on this model, we can model the fault of the power system effectively and can deal with the incomplete information.

2) The calculation of B function in the Bayesian Petri nets is actually Bayesian probability calculation, and we use the statistical prior probability to calculate the probability of component fault. So the results have high credibility. And we can avoid the subjectivity from setting calculation parameters directly that the modeling is based on the common Petri nets reasoning method.

3) The BPN model is established based on the analysis method which is used respectively on every fault spread direction of the relay protection. It can effectively reduce the complexity of the calculation and simplify the model. The process of diagnosis analysis shows that the model with incomplete information has better ability of fault tolerance and has better adaptability of the topology change.

Acknowledgements

This work is supported by the National Natural Science Foundation of China under Grant No. 61170223 and No. U1204610, the Key Scientific and Technological Research Project of Science and Technology Department of Henan Province of China No. 122102210004, and the National Key Technology R&D Program of the Ministry of Science and Technology of China No. 2013BAH23F01. Thanks for the help.

References

- [1]. Wang Jialin, Xia Li And Wu Zhengguo, State of arts of fault diagnosis of power systems, *Power System*

Protection and Control, Vol. 38, Issue 18, 2010, pp. 210-216.

- [2]. C. Angeli, Online expert systems for fault diagnosis in technical processes, *Expert Systems*, Vol. 25, Issue 2, 2008, pp. 115-132.
- [3]. Liu Chao, He Zhengyou, and Yang Jianwei, A quantum neural network based fault diagnosis algorithm for power grid, *Power System Technology*, Vol. 32, Issue 9, 2008, pp. 57-60.
- [4]. Li Ran, Gao Congying, and Zhang Lieyong, The distributed fault diagnosis of power networks based on Bayesian rough set method, *Journal of North China Electric Power University*, Vol. 37, No. 2, 2011, pp. 1-7.
- [5]. Ye Yangdong, Cheng Shaofen, and Wang Xu, Modeling and analyzing of train operation systems based on a kind of hybrid Petri net, *Journal of the China Railway Society*, Vol. 31, No. 5, 2009, pp. 42-49.
- [6]. Lin Zhenzhi, Wen Fushuan, and Zhong Zhiyong, Applications of Petri nets in power systems, *Proceedings of the CSU-EPSA*, Vol. 19, Issue 5, 2007, pp. 14-21.
- [7]. K. L. Lo, H. S. Ng, and J. Trecat, Power systems fault diagnosis using Petri nets, *IEEE Proceedings on Generations, Transmissions and Distributions*, Vol. 144, Issue 3, 1997, pp. 231-236.
- [8]. Ren Hui, Mi Zengqiang, and Zhao Hongshan, Power system fault diagnosis modeling techniques based on encoded Petri nets, in *Proceedings of the CSEE*, Vol. 20, Issue 25, 2005, pp. 44-49.
- [9]. Tian Baojiang, Application of Petri net in power grid fault diagnosis, Ph.D. Thesis, *Shandong University*, 2008.
- [10]. Yang Jianwei, He Zhengyou, and Zang Tianlei. Power system fault-diagnosis method based on directional weighted fuzzy Petri nets, in *Proceedings of the CSEE*, Vol. 30, Issue 34, 2010, pp. 42-49.
- [11]. Wu Xin, Guo Chuangxin, and Cao Yijia, A new fault diagnosis approach of power system based on Bayesian network and temporal order information, *Proceedings of the CSEE*, Vol. 25, Issue 13, 2005, pp. 14-18.
- [12]. Zhang Yang, Power system fault diagnosis based on DS evidence theory and mutual information network, Ph.D. Thesis, *South-West Jiaotong University*, 2010.