

ISSN 1726-5749

SENSORS & TRANSDUCERS

vol. 89
3/08



Smart Sensors and Systems

International Frequency Sensor Association Publishing





Sensors & Transducers

Volume 89
Issue 3
March 2008

www.sensorsportal.com

ISSN 1726-5479

Editor-in-Chief: professor Sergey Y. Yurish, phone: +34 696067716, fax: +34 93 4011989,
e-mail: editor@sensorsportal.com

Editors for Western Europe

Meijer, Gerard C.M., Delft University of Technology, The Netherlands
Ferrari, Vittorio, Università di Brescia, Italy

Editors for North America

Datskos, Panos G., Oak Ridge National Laboratory, USA
Fabien, J. Josse, Marquette University, USA
Katz, Evgeny, Clarkson University, USA

Editor South America

Costa-Felix, Rodrigo, Inmetro, Brazil

Editor for Eastern Europe

Sachenko, Anatoly, Ternopil State Economic University, Ukraine

Editor for Asia

Ohyama, Shinji, Tokyo Institute of Technology, Japan

Editorial Advisory Board

- Abdul Rahim, Ruzairi**, Universiti Teknologi, Malaysia
Ahmad, Mohd Noor, Northern University of Engineering, Malaysia
Annamalai, Karthigeyan, National Institute of Advanced Industrial Science and Technology, Japan
Arcega, Francisco, University of Zaragoza, Spain
Arguel, Philippe, CNRS, France
Ahn, Jae-Pyong, Korea Institute of Science and Technology, Korea
Arndt, Michael, Robert Bosch GmbH, Germany
Ascoli, Giorgio, George Mason University, USA
Atalay, Selcuk, Inonu University, Turkey
Atghiaee, Ahmad, University of Tehran, Iran
Augutis, Vygantas, Kaunas University of Technology, Lithuania
Avachit, Patil Lalchand, North Maharashtra University, India
Ayesh, Aladdin, De Montfort University, UK
Bahreyni, Behraad, University of Manitoba, Canada
Baoxian, Ye, Zhengzhou University, China
Barford, Lee, Agilent Laboratories, USA
Barlingay, Ravindra, RF Arrays Systems, India
Basu, Sukumar, Jadavpur University, India
Beck, Stephen, University of Sheffield, UK
Ben Bouzid, Sihem, Institut National de Recherche Scientifique, Tunisia
Binnie, T. David, Napier University, UK
Bischoff, Gerlinde, Inst. Analytical Chemistry, Germany
Bodas, Dhananjay, IMTEK, Germany
Borges Carval, Nuno, Universidade de Aveiro, Portugal
Bousbia-Salah, Mounir, University of Annaba, Algeria
Bouvet, Marcel, CNRS – UPMC, France
Brudzewski, Kazimierz, Warsaw University of Technology, Poland
Cai, Chenxin, Nanjing Normal University, China
Cai, Qingyun, Hunan University, China
Campanella, Luigi, University La Sapienza, Italy
Carvalho, Vitor, Minho University, Portugal
Cecelja, Franjo, Brunel University, London, UK
Cerda Belmonte, Judith, Imperial College London, UK
Chakrabarty, Chandan Kumar, Universiti Tenaga Nasional, Malaysia
Chakravorty, Dipankar, Association for the Cultivation of Science, India
Changhai, Ru, Harbin Engineering University, China
Chaudhari, Gajanan, Shri Shivaji Science College, India
Chen, Rongshun, National Tsing Hua University, Taiwan
Cheng, Kuo-Sheng, National Cheng Kung University, Taiwan
Chiriac, Horia, National Institute of Research and Development, Romania
Chowdhuri, Arijit, University of Delhi, India
Chung, Wen-Yaw, Chung Yuan Christian University, Taiwan
Corres, Jesus, Universidad Publica de Navarra, Spain
Cortes, Camilo A., Universidad Nacional de Colombia, Colombia
Courtois, Christian, Universite de Valenciennes, France
Cusano, Andrea, University of Sannio, Italy
D'Amico, Arnaldo, Università di Tor Vergata, Italy
De Stefano, Luca, Institute for Microelectronics and Microsystem, Italy
Deshmukh, Kiran, Shri Shivaji Mahavidyalaya, Barshi, India
Kang, Moonho, Sunmoon University, Korea South
Kaniusas, Eugenijus, Vienna University of Technology, Austria
Katake, Anup, Texas A&M University, USA
Kausel, Wilfried, University of Music, Vienna, Austria
Kavasoglu, Nese, Mugla University, Turkey
Ke, Cathy, Tyndall National Institute, Ireland
Dickert, Franz L., Vienna University, Austria
Dieguez, Angel, University of Barcelona, Spain
Dimitropoulos, Panos, University of Thessaly, Greece
Ding Jian, Ning, Jiangsu University, China
Djordjevic, Alexandar, City University of Hong Kong, Hong Kong
Donato, Nicola, University of Messina, Italy
Donato, Patricio, Universidad de Mar del Plata, Argentina
Dong, Feng, Tianjin University, China
Drjaca, Predrag, Instersema Sensoric SA, Switzerland
Dubey, Venketesh, Bournemouth University, UK
Enderle, Stefan, University of Ulm and KTB mechatronics GmbH, Germany
Erdem, Gursan K. Arzum, Ege University, Turkey
Erkmen, Aydan M., Middle East Technical University, Turkey
Estelle, Patrice, Insa Rennes, France
Estrada, Horacio, University of North Carolina, USA
Faiz, Adil, INSA Lyon, France
Fericean, Sorin, Balluff GmbH, Germany
Fernandes, Joana M., University of Porto, Portugal
Francioso, Luca, CNR-IMM Institute for Microelectronics and Microsystems, Italy
Francis, Laurent, University Catholique de Louvain, Belgium
Fu, Weiling, South-Western Hospital, Chongqing, China
Gaura, Elena, Coventry University, UK
Geng, Yanfeng, China University of Petroleum, China
Gole, James, Georgia Institute of Technology, USA
Gong, Hao, National University of Singapore, Singapore
Gonzalez de la Rosa, Juan Jose, University of Cadiz, Spain
Grael, Annette, Goteborg University, Sweden
Graff, Mason, The University of Texas at Arlington, USA
Guan, Shan, Eastman Kodak, USA
Guillet, Bruno, University of Caen, France
Guo, Zhen, New Jersey Institute of Technology, USA
Gupta, Narendra Kumar, Napier University, UK
Hadjiloucas, Sillas, The University of Reading, UK
Hashsham, Syed, Michigan State University, USA
Hernandez, Alvaro, University of Alcala, Spain
Hernandez, Wilmar, Universidad Politecnica de Madrid, Spain
Homentcovschi, Dorel, SUNY Binghamton, USA
Horstman, Tom, U.S. Automation Group, LLC, USA
Hsiai, Tzung (John), University of Southern California, USA
Huang, Jeng-Sheng, Chung Yuan Christian University, Taiwan
Huang, Star, National Tsing Hua University, Taiwan
Huang, Wei, PSG Design Center, USA
Hui, David, University of New Orleans, USA
Jaffrezic-Renault, Nicole, Ecole Centrale de Lyon, France
Jaime Calvo-Galleg, Jaime, Universidad de Salamanca, Spain
James, Daniel, Griffith University, Australia
Janting, Jakob, DELTA Danish Electronics, Denmark
Jiang, Liudi, University of Southampton, UK
Jiao, Zheng, Shanghai University, China
John, Joachim, IMEC, Belgium
Kalach, Andrew, Voronezh Institute of Ministry of Interior, Russia
Rodriguez, Angel, Universidad Politecnica de Cataluna, Spain
Rothberg, Steve, Loughborough University, UK
Sadana, Ajit, University of Mississippi, USA

Khan, Asif, Aligarh Muslim University, Aligarh, India
Kim, Min Young, Koh Young Technology, Inc., Korea South
Ko, Sang Choon, Electronics and Telecommunications Research Institute, Korea South
Kockar, Hakan, Balikesir University, Turkey
Kotulska, Malgorzata, Wroclaw University of Technology, Poland
Kratz, Henrik, Uppsala University, Sweden
Kumar, Arun, University of South Florida, USA
Kumar, Subodh, National Physical Laboratory, India
Kung, Chih-Hsien, Chang-Jung Christian University, Taiwan
Lacnjevac, Caslav, University of Belgrade, Serbia
Lay-Ekuakille, Aime, University of Lecce, Italy
Lee, Jang Myung, Pusan National University, Korea South
Lee, Jun Su, Amkor Technology, Inc. South Korea
Lei, Hua, National Starch and Chemical Company, USA
Li, Genxi, Nanjing University, China
Li, Hui, Shanghai Jiaotong University, China
Li, Xian-Fang, Central South University, China
Liang, Yuanchang, University of Washington, USA
Liawruangrath, Saisunee, Chiang Mai University, Thailand
Liew, Kim Meow, City University of Hong Kong, Hong Kong
Lin, Hermann, National Kaohsiung University, Taiwan
Lin, Paul, Cleveland State University, USA
Linderholm, Pontus, EPFL - Microsystems Laboratory, Switzerland
Liu, Aihua, University of Oklahoma, USA
Liu Changgeng, Louisiana State University, USA
Liu, Cheng-Hsien, National Tsing Hua University, Taiwan
Liu, Songqin, Southeast University, China
Lodeiro, Carlos, Universidade NOVA de Lisboa, Portugal
Lorenzo, Maria Encarnacio, Universidad Autonoma de Madrid, Spain
Lukaszewicz, Jerzy Pawel, Nicholas Copernicus University, Poland
Ma, Zhanfang, Northeast Normal University, China
Majstorovic, Vidosav, University of Belgrade, Serbia
Marquez, Alfredo, Centro de Investigacion en Materiales Avanzados, Mexico
Matay, Ladislav, Slovak Academy of Sciences, Slovakia
Mathur, Prafull, National Physical Laboratory, India
Maurya, D.K., Institute of Materials Research and Engineering, Singapore
Mekid, Samir, University of Manchester, UK
Melnyk, Ivan, Photon Control Inc., Canada
Mendes, Paulo, University of Minho, Portugal
Mennell, Julie, Northumbria University, UK
Mi, Bin, Boston Scientific Corporation, USA
Minas, Graca, University of Minho, Portugal
Moghavvemi, Mahmoud, University of Malaya, Malaysia
Mohammadi, Mohammad-Reza, University of Cambridge, UK
Molina Flores, Esteban, Benemérita Universidad Autónoma de Puebla, Mexico
Moradi, Majid, University of Kerman, Iran
Morello, Rosario, DIMET, University "Mediterranea" of Reggio Calabria, Italy
Mounir, Ben Ali, University of Sousse, Tunisia
Mukhopadhyay, Subhas, Massey University, New Zealand
Neelamegam, Periasamy, Sastra Deemed University, India
Neshkova, Milka, Bulgarian Academy of Sciences, Bulgaria
Oberhammer, Joachim, Royal Institute of Technology, Sweden
Ould Lahoucine, University of Guelma, Algeria
Pamidighanta, Sayanu, Bharat Electronics Limited (BEL), India
Pan, Jisheng, Institute of Materials Research & Engineering, Singapore
Park, Joon-Shik, Korea Electronics Technology Institute, Korea South
Penza, Michele, ENEA C.R., Italy
Pereira, Jose Miguel, Instituto Politecnico de Seteбал, Portugal
Petsev, Dimitar, University of New Mexico, USA
Pogacnik, Lea, University of Ljubljana, Slovenia
Post, Michael, National Research Council, Canada
Prance, Robert, University of Sussex, UK
Prasad, Ambika, Gulbarga University, India
Prateepasen, Asa, Kingmoungut's University of Technology, Thailand
Pullini, Daniele, Centro Ricerche FIAT, Italy
Pumera, Martin, National Institute for Materials Science, Japan
Radhakrishnan, S., National Chemical Laboratory, Pune, India
Rajanna, K., Indian Institute of Science, India
Ramadan, Qasem, Institute of Microelectronics, Singapore
Rao, Basuthkar, Tata Inst. of Fundamental Research, India
Raouf, Kosai, Joseph Fourier University of Grenoble, France
Reig, Candid, University of Valencia, Spain
Restivo, Maria Teresa, University of Porto, Portugal
Robert, Michel, University Henri Poincare, France
Rezazadeh, Ghader, Urmia University, Iran
Royo, Santiago, Universitat Politecnica de Catalunya, Spain
Sadeghian Marnani, Hamed, TU Delft, The Netherlands
Sandacci, Serghei, Sensor Technology Ltd., UK
Sapozhnikova, Ksenia, D.I.Mendeleyev Institute for Metrology, Russia
Saxena, Vibha, Bhabha Atomic Research Centre, Mumbai, India
Schneider, John K., Ultra-Scan Corporation, USA
Seif, Selemeni, Alabama A & M University, USA
Seifter, Achim, Los Alamos National Laboratory, USA
Sengupta, Deepak, Advance Bio-Photonics, India
Shearwood, Christopher, Nanyang Technological University, Singapore
Shin, Kyuho, Samsung Advanced Institute of Technology, Korea
Shmaliy, Yuriy, Kharkiv National University of Radio Electronics, Ukraine
Silva Girao, Pedro, Technical University of Lisbon Portugal
Singh, V. R., National Physical Laboratory, India
Slomovitz, Daniel, UTE, Uruguay
Smith, Martin, Open University, UK
Soleymanpour, Ahmad, Damghan Basic Science University, Iran
Somani, Prakash R., Centre for Materials for Electronics Technol., India
Srinivas, Talabattula, Indian Institute of Science, Bangalore, India
Srivastava, Arvind K., Northwestern University
Stefan-van Staden, Raluca-Ioana, University of Pretoria, South Africa
Sun, Sumritdetchka, Sarun, National Electronics and Computer Technology Center, Thailand
Sun, Chengliang, Polytechnic University, Hong-Kong
Sun, Dongming, Jilin University, China
Sun, Junhua, Beijing University of Aeronautics and Astronautics, China
Sun, Zhiqiang, Central South University, China
Suri, C. Raman, Institute of Microbial Technology, India
Sysoev, Victor, Saratov State Technical University, Russia
Szewczyk, Roman, Industrial Research Institute for Automation and Measurement, Poland
Tan, Ooi Kiang, Nanyang Technological University, Singapore
Tang, Dianping, Southwest University, China
Tang, Jaw-Luen, National Chung Cheng University, Taiwan
Teker, Kasif, Frostburg State University, USA
Thumbavanam Pad, Kartik, Carnegie Mellon University, USA
Tsiantos, Vassilios, Technological Educational Institute of Kaval, Greece
Tsigara, Anna, National Hellenic Research Foundation, Greece
Twomey, Karen, University College Cork, Ireland
Valente, Antonio, University, Vila Real, - U.T.A.D., Portugal
Vaseashta, Ashok, Marshall University, USA
Vazques, Carmen, Carlos III University in Madrid, Spain
Vieira, Manuela, Instituto Superior de Engenharia de Lisboa, Portugal
Vigna, Benedetto, STMicroelectronics, Italy
Vrba, Radimir, Brno University of Technology, Czech Republic
Wandelt, Barbara, Technical University of Lodz, Poland
Wang, Jiangping, Xi'an Shiyou University, China
Wang, Kedong, Beihang University, China
Wang, Liang, Advanced Micro Devices, USA
Wang, Mi, University of Leeds, UK
Wang, Shinn-Fwu, Ching Yun University, Taiwan
Wang, Wei-Chih, University of Washington, USA
Wang, Wensheng, University of Pennsylvania, USA
Watson, Steven, Center for NanoSpace Technologies Inc., USA
Weiping, Yan, Dalian University of Technology, China
Wells, Stephen, Southern Company Services, USA
Wolkenberg, Andrzej, Institute of Electron Technology, Poland
Woods, R. Clive, Louisiana State University, USA
Wu, DerHo, National Pingtung University of Science and Technology, Taiwan
Wu, Zhaoyang, Hunan University, China
Xiu Tao, Ge, Chuzhou University, China
Xu, Lisheng, The Chinese University of Hong Kong
Xu, Tao, University of California, Irvine, USA
Yang, Dongfang, National Research Council, Canada
Yang, Wuqiang, The University of Manchester, UK
Ymeti, Aurel, University of Twente, Netherland
Yu, Haihu, Wuhan University of Technology, China
Yufera Garcia, Alberto, Seville University, Spain
Zagnoni, Michele, University of Southampton, UK
Zeni, Luigi, Second University of Naples, Italy
Zhong, Haoxiang, Henan Normal University, China
Zhang, Minglong, Shanghai University, China
Zhang, Qintao, University of California at Berkeley, USA
Zhang, Weiping, Shanghai Jiao Tong University, China
Zhang, Wenming, Shanghai Jiao Tong University, China
Zhou, Zhi-Gang, Tsinghua University, China
Zorzano, Luis, Universidad de La Rioja, Spain
Zourob, Mohammed, University of Cambridge, UK

Contents

Volume 89
Issue 3
March 2008

www.sensorsportal.com

ISSN 1726-5479

Research Articles

Use of Smart Sensors in the Measurement of Power Quality <i>A. Moreno-Muñoz, and J. J. G. de la Rosa</i>	1
A Multi-Channel, High-Precision Sensor Interface for Low-Power Applications – ZMD21013 <i>Marko Mailand</i>	10
Studying of a Tunneling Accelerometer with Piezoelectric Actuation and Fuzzy Controller <i>Ahmadali Tahmasebi Moradi, Yousef Kanani, Behrouz Tousi, Asadollah Motalebi, and Ghader Rezazadeh</i>	17
Control of Neutralization Process Using Soft Computing <i>G. Balasubramanian, N. Sivakumaran and T. K. Radhakrishnan</i>	30
Artificially Controlling the Limb Movement of Robotic Arm Using Machine Interface with EMG Sensor <i>Govind Singh Patel, Amrita Rai and Dr. S. Prasad</i>	39
Active Vibration Control of a Flexible Structure Using Piezoceramic Actuators <i>J. Fei</i>	52
Analysis and Implementation of Nonlinear Transducer Response over a Wider Response Range <i>Sheroz Khan, AHM Zahirul Alam, Syed Masrur Ahmmad, TIJANI I. B., Muhammad Asraful Hasan, Lawal Wahab Adetunji, Salami Femi Abdulazeez, Siti Hana Mohammad Zaini, Siti Aminah Othman, Saman S. Khan</i>	61
Leak Detection and Model Analysis for Nonlinear Spherical Tank Process Using Conductivity Sensor <i>P. Madhavasarma, S. Sundaram</i>	71
Analytical and Fundamental Study of EMATs System <i>A. Doniavi, M. Eskandarzade, J. Malekani</i>	77
A Modified Design of an Anemometric Flow Transducer <i>S. C. Bera and N. Mandal</i>	83
A Novel Hybrid Binary Reconstruction Algorithm for Ultrasonic Tomography <i>M. H. Fazalul Rahiman and R. Abdul Rahim</i>	93

Authors are encouraged to submit article in MS Word (doc) and Acrobat (pdf) formats by e-mail: editor@sensorsportal.com
Please visit journal's webpage with preparation instructions: <http://www.sensorsportal.com/HTML/DIGEST/Submission.htm>



Leak Detection and Model Analysis for Nonlinear Spherical Tank Process Using Conductivity Sensor

P. Madhavasarma, S. Sundaram

Department of Electronics & Instrumentation Engineering, Sastra University
Thanjavur 613402 Tamilnadu, India

Tel.: +91(04362)264101, extn: 262, fax: +91(04362)264120

E-mail: Spms1975@eie.sastra.edu, ssundar@sastra.edu

Received: 25 February 2008 /Accepted: 17 March 2008 /Published: 24 March 2008

Abstract: Model parameters are affected by leak in process plants and this leak can be considered as disturbance in model evaluation. A non linear spherical tank of 40 liter capacity was used for this study. Process Model was generated experimentally using step response technique with online conductivity as monitoring parameter. A microcontroller using ATMEGA16 was used for the measurement of conductivity with and without leak of process liquid. The process model parameters were affected due to leak up to seventeen percent in the range of flow rates studied. *Copyright © 2008 IFSA.*

Keywords: Leak, Tracer, Model, Conductivity, Microcontroller, Spherical

1. Introduction

Leakage in pipes and process vessels can affect to varying degree the model parameters as well as product quality. Many authors [1-7] have used conductivity to develop models. Moreno et al. [8] have used conductivity to control water quality. Billmann [9] has designed a liquid flow sensor for detection of leak in pipes. Hiroki [10] has developed a unit for water leak detection in fusion reactors. Verde [11], Bausch et al. [12], and Convey [13] have also studied leak in pipelines. Nelemegam et al. [14] have used Microcontroller to evaluate conductivity. These authors have not analyzed the effect of leak on model parameters. This work quantitatively analyses the effect of leak of process fluid on model parameters.

2. Experimental Setup

Fig.1 shows the setup used in this study. A concentrated sodium chloride tracer solution and fresh water are fed to a 40 liter spherical tank through suitable rotameters. Online conductivity sensor from M/s Honeywell in the exit pipe measures the conductivity of the flowing liquid. The signal is suitably modified and interfaced with an inbuilt ADC (PA0) of a microcontroller. The microcontroller ATmega16 is a low power, high performance 8 bit microcontroller. It has 16 k Bytes of in-system Self-Programming Flash, 1K Byte internal static RAM, 512 bytes EEPROM, two 8 bit timer/counter, one 16 bit timer/counter, 8 channel 10 bit ADC, 4 PWM channels, programmable serial UART, on chip analog comparator and 32 programmable I/O lines. Two row 16 character alpha numeric LCD display is interfaced to port D of the microcontroller to display the results. A key board is interfaced with PORT C of microcontroller. An ICL232 chip is interfaced with microcontroller to transmit and receive data from PC. ICL232 IC chip is a dual RS232 transmitter/receiver interface circuit that meets all EIA RS232 specification. The input side of the chip is connected to TxD/RxD pin of microcontroller and the output side of ICL232 is connected to COM1 port of PC.

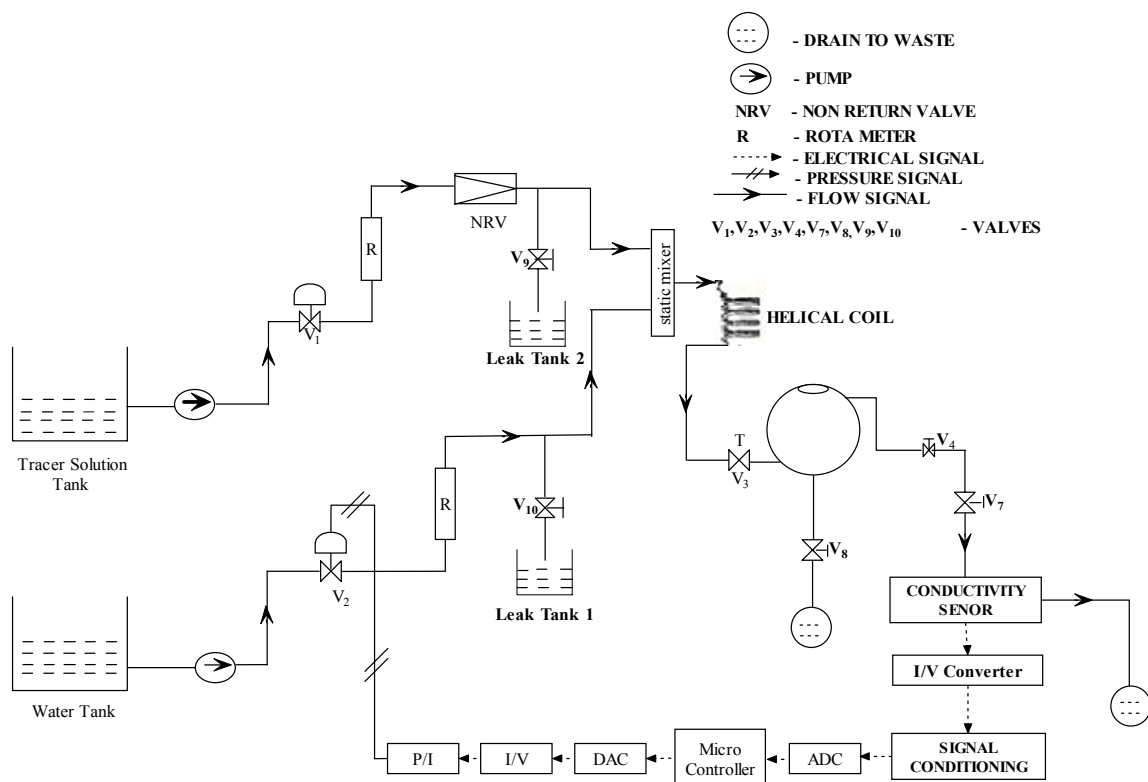

Fig. 1. Experimental setup for leak measurement.

2.1. Calibration

Conductivity sensor was calibrated with known solutions of sodium chloride. Fig.2. shows the calibration curve.

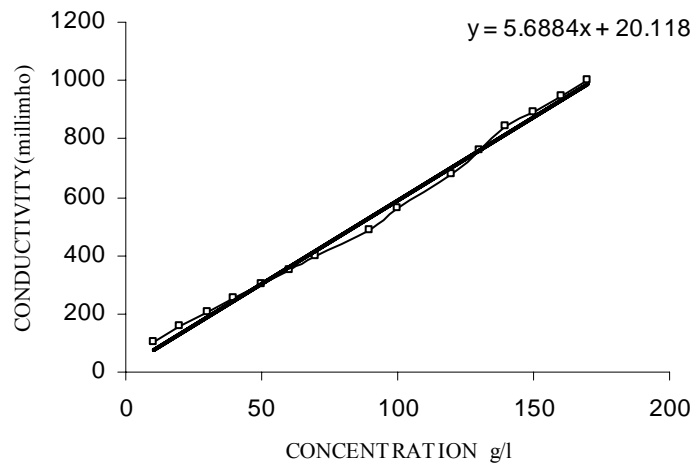

Fig. 2. Calibration curve for conductivity sensor with known concentration.

2.2. Measurement Procedure

The process flow model was established [15] by open loop analysis by varying water flow rates from 2 to 5 lpm. Tracer was injected as a step from 0 to 0.5 lpm. The outlet conductivity was recorded. A leak of different magnitude was introduced in the pipeline by manipulating valve V_{10} for pure water. The exit conductivity with leak was also measured.

2.3. Software

Software was developed in C language to initialize the LCD display, serial port, to start ADC conversion, to check end of conversion, to read data from ADC, to compute conductivity of the sample, for measurement of time, data computation for acquired data, storage of data and to send data to PC, to receive data from PC. The software is compiled by C compiler and the resulting codes are stored in the program memory of the ATmega16 microcontroller and the program was executed for measurement of conductivity with and without leak.

2.4. Model Analysis

The data in Figs. 3 to 5 was fitted to a first order plus dead time model [16] given by equation 1. where K_p is the process gain, τ_d the time delay and τ is the process time constant. The model parameters with and without leak are given in Table 2.

$$G_p(s) = \frac{K_p e^{(-\tau_d s)}}{\tau s + 1} \quad (1)$$

3. Results and Discussion

The variation of conductivity with and without leak for various flow rates of water are given in Figs. 3 to 5. Varying quantity of leak (as a fraction of main flow rate) is introduced after initial stabilization by manipulating valve V_{10} and is indicated by arrow mark in Figures 3 to 5. Table 1 records the leak induced and the corresponding error in final value of conductivity. Table 2 gives the model parameters

with and without leak. The process gain (K_p) and time constant (τ_p) are affected from 5 to 58 percent due to leak as seen from Table 2.

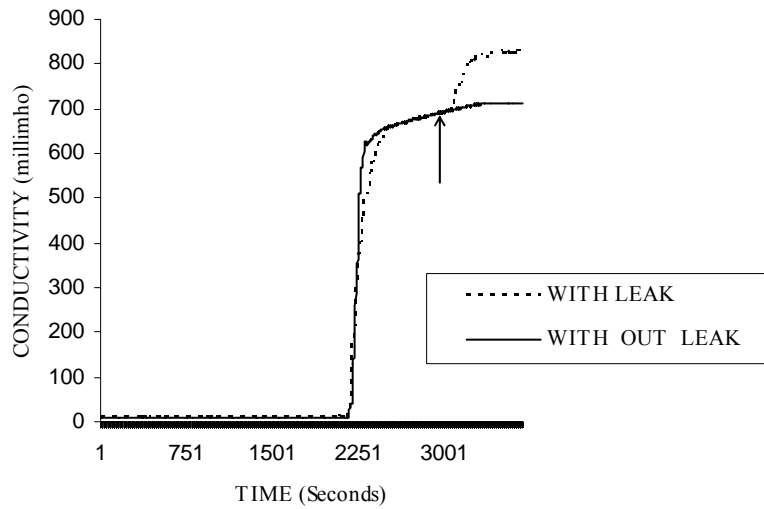

Fig. 3. Response for 50 percentage leak of water.

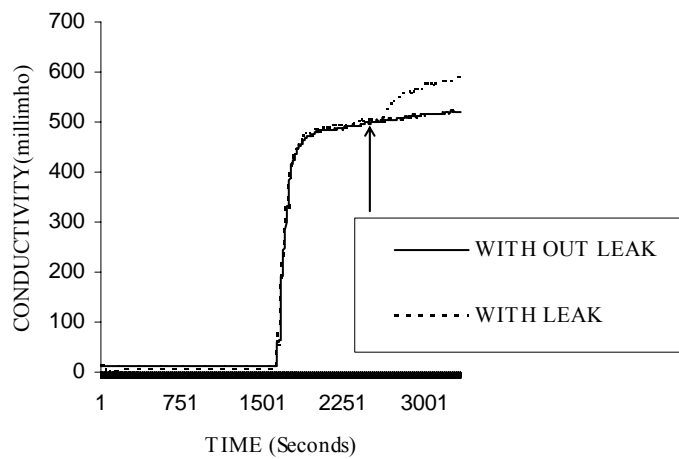

Fig. 4. Response for 66 percentage of leak of water.

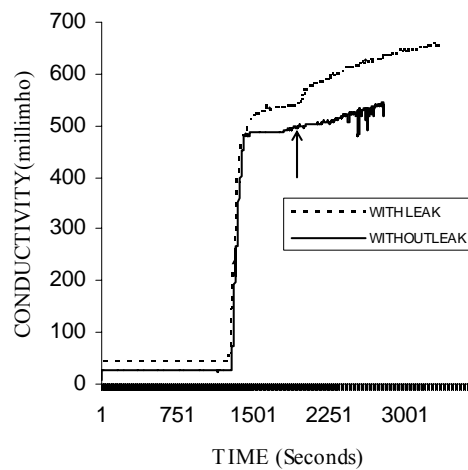

Fig. 5. Response for 75 percentage of leak of water.

Table 1. Effect of leak on final value of conductivity.

S.No	Main flow rate lit/min	Leak flow rate lit/min	Percentage leak ((Main flow-leak flow) / Main flow)) x 100	Final Conductivity Value millimho/cm		Percentage error in conductivity
				Without Leak	With Leak	
1	2	1	50	700	830	15
2	3	1	66	560	620	16
3	4	1	75	490	590	17

Table 2. Model Parameter with and without leak for various flow rates.

S.No	Leak ratio (%)	Main Flow rate(lit/min)	Model parameters							
			Without leak			With leak			% change due to leak	
			Process Gain (K _p)	Time constant Secs (τ _p)	Delay Time Secs (τ _d)	Process Gain (K _p)	Time Constant Secs (τ _p)	Delay Time Secs (τ _d)	Process Gain (K _p)	Time Constant Secs (τ _p)
1	75	4	5.46	27	1400	5.75	36	2000	5	33.3
2	66	3	6.25	36	1500	8.31	55	2525	32	52.8
3	50	2	8.38	42	2000	13.3	60	2900	58	42.8

4. Conclusion

Model parameter analysis and leak detection based on microcontroller for a non linear spherical process has been studied. Their characteristics based on delay time, time constant, process gain are compared for both processes. From Table 2 it is observed that due to leak in the process, model parameters are affected and also conductivity level varies from 15 percent to 17 percent. This shows that leak adversely affects model analysis and effective care should be taken.

References

- [1]. J. Hubalek, J. Krejci, Correction factors of IDEs for precise conductivity measurements, *Sens. Actuators, B: Chem.*, 91, 2003, pp. 46-51.
- [2]. P. Madhavasarma, S. Sundaram, Model based tuning of controller for non linear hemispherical tank processes, *Instrumentation Science Technology*, 35, 2007, pp. 681-689.
- [3]. A. C. de Paula, M. Ferrari, D. M. Soares, V. Ferrari, Modeling and experiments on quartz crystal resonator sensor for conductivity measurements of low concentration ionic solutions, *J. Sensors & Transducers*, 71, 2006, pp. 711-720.
- [4]. J. Arputha Vijayaselvi, T. K. Radhakrishnan, S. Sundaram, Model based IMC controller for process with dead time, *Instrum. Sci & Technology*, 34, 2006, pp. 463-474.
- [5]. A. D. Fitt, J. R. Owen, Simultaneous measurements of conductivity and thickness for polymer electrolyte films a simple study, *Electroanalyticalchemistry*, 539, 2003, pp. 13-23.
- [6]. R. G. Jones, Measurements of the electrical conductivity of water, *IEEE Proc. Sci. Meas & Technol.*, 149, 2002, pp. 320-322.
- [7]. P. Madhavasarma, S. Sundaram, Model based evaluation of controller using flow sensor for conductivity process, *J. Sensors & Transducers*, 79, 2007, pp. 1164-1172.
- [8]. L. Moreno, A. Merlos, N. Abramova, C. Jimenez, A. Bratov, Multi-sensor array used as an electronic tongue for mineral water analysis, *Sens. Actuators, B: Chem*, 116, 2006, pp. 130-134.

- [9]. L. Billmann, R. Isermann, Leak detection methods for pipelines, *J. Automatica*, 23, 1987, pp. 381-385.
- [10].S. Hiroki, S. Tanzawa, T. Arai, T. Abe, Development of water leak detection method in fusion reactors using water solubalegas, *Fusion Engineering and design*, 2007, Article in press.
- [11].C. Verde, Multi-leak detection and isolation in fluid pipelines, *Control Engineering Practice*, 9, 2001, pp. 673-682.
- [12].H. P. Bausch, V. K. Chexal, J. S. Horowitz, Leak detection in nuclear piping outside containiment, *J. Nuclear Engineering and Design*, 1139, 1989, pp. 155-162.
- [13].H. J. Convey, M. J. Booth, Development of water leak detection system, *Computing Control Engineering*, 13, 2002, pp. 33-38.
- [14].A. Rajenderan, P. Neelamegam, Measurement of conductivity of liquids using AT89C55WD microcontroller, *Measurement*, 35, 2004, pp. 59-63.
- [15].J. Arputha Vijayaselvi, T. K. Radhakrishnan, S. Sundaram, Performance assessment of PID and IMC tuning methods for a mixing process with time delay, *ISA.*, 46, 2007, pp. 391-397.
- [16].P. Madhavasarma, T. K Radhakrishnan, S. Sundaram, Model based evaluation of controller using pole placement technique, *J. Instrum. Soc. India*, 2006, pp. 246-256.

2008Copyright ©, International Frequency Sensor Association (IFSA). All rights reserved.
(<http://www.sensorsportal.com>)

IDGA Institute for Defense and Government Advancement Presents:

3rd Annual

Military Armor Protection™

Advancing Vehicle and Body Armor Protection in an Asymmetric Environment

May 19-22, 2008 | The Westin Alexandria
Alexandria, VA

Sponsored by: **CeramTec** **COORSTEK**
Amazing Solutions™

Plus 2 in-depth workshop days on Armor Materials and Advancements in Armor!

Mention code
IFSA & SAVE \$100

Mission-critical topics include:

- Unidirectional Body Armor Systems to Defeat EFPs and IEDs
- Innovations in Survivability of Ground Vehicles
- Design and Performance Improvements for Individual Ballistic Protection

www.idga.org/us/map/ifsa

Guide for Contributors

Aims and Scope

Sensors & Transducers Journal (ISSN 1726-5479) provides an advanced forum for the science and technology of physical, chemical sensors and biosensors. It publishes state-of-the-art reviews, regular research and application specific papers, short notes, letters to Editor and sensors related books reviews as well as academic, practical and commercial information of interest to its readership. Because it is an open access, peer review international journal, papers rapidly published in *Sensors & Transducers Journal* will receive a very high publicity. The journal is published monthly as twelve issues per annual by International Frequency Association (IFSA). In addition, some special sponsored and conference issues published annually.

Topics Covered

Contributions are invited on all aspects of research, development and application of the science and technology of sensors, transducers and sensor instrumentations. Topics include, but are not restricted to:

- Physical, chemical and biosensors;
- Digital, frequency, period, duty-cycle, time interval, PWM, pulse number output sensors and transducers;
- Theory, principles, effects, design, standardization and modeling;
- Smart sensors and systems;
- Sensor instrumentation;
- Virtual instruments;
- Sensors interfaces, buses and networks;
- Signal processing;
- Frequency (period, duty-cycle)-to-digital converters, ADC;
- Technologies and materials;
- Nanosensors;
- Microsystems;
- Applications.

Submission of papers

Articles should be written in English. Authors are invited to submit by e-mail editor@sensorsportal.com 6-14 pages article (including abstract, illustrations (color or grayscale), photos and references) in both: MS Word (doc) and Acrobat (pdf) formats. Detailed preparation instructions, paper example and template of manuscript are available from the journal's webpage: <http://www.sensorsportal.com/HTML/DIGEST/Submission.htm> Authors must follow the instructions strictly when submitting their manuscripts.

Advertising Information

Advertising orders and enquires may be sent to sales@sensorsportal.com Please download also our media kit: http://www.sensorsportal.com/DOWNLOADS/Media_Kit_2008.pdf



KNOWLEDGE FOR GENERATIONS

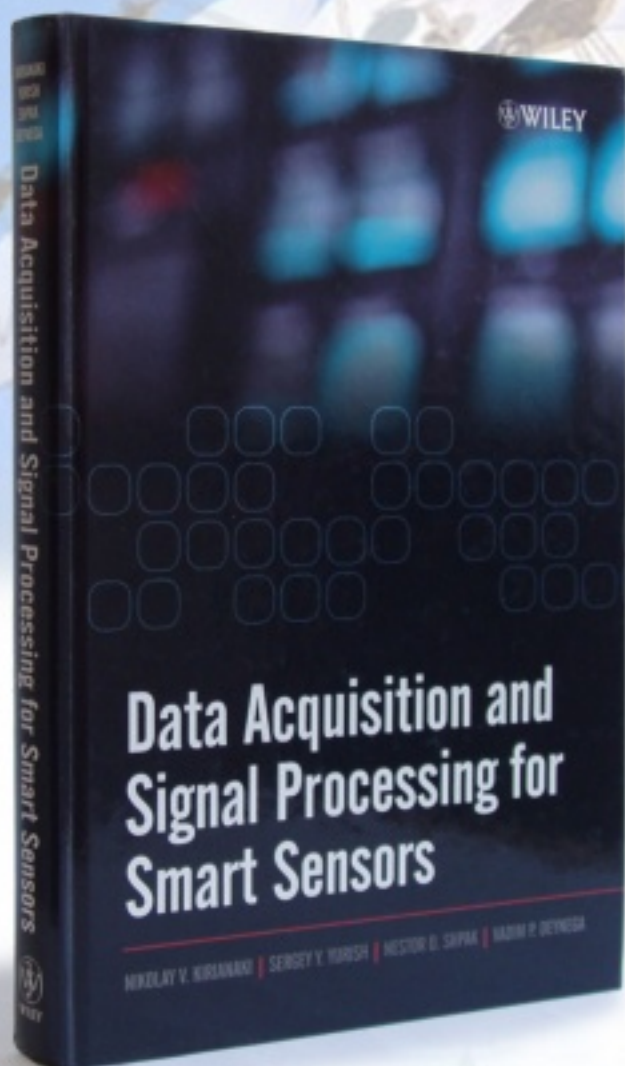

'This book provides a good basis for anyone entering or studying the field of smart sensors not only for the inexperienced but also very useful to those with some experience'

(from IEEE Instrumentation & Measurement Magazine review)



Order online:

http://www.sensorsportal.com/HTML/BOOKSTORE/DAQ_SP.htm

www.sensorsportal.com