

Design and Evaluation of a Low-Cost and Flexible Data Acquisition System Using Sensor Network for Smart Homes

* **Sani ABBA and Itse Musa NYAM**

Abubakar Tafawa Balewa University (Federal University of Technology), ATBU,
Yelwa campus Dass road, P.M.B. 0248, Bauchi State, Nigeria
Tel.: + 234 0811 9717 843

* E-mail: saniabba2004@gmail.com

Received: 31 July 2018 /Accepted: 28 September 2018 /Published: 30 November 2018

Abstract: This research paper presents the design and performance evaluation of a low-cost and flexible data acquisition system using sensor network. This work, is an extension of our previous conference paper [24]. The study considers three important parameters for performance evaluation. Namely, temperature, humidity and light. Proteus and Arduino integrated design environment is used to build a complete sensor network. A real working prototype was designed and implemented. Experimental procedure includes building the hardware architecture of the transmitting nodes, modeling both the communication channels and the receiving master node. A low-cost digital-output relative humidity and temperature, and light dependent-resistor sensors were used for the data acquisition system. The values of the sensed parameters are stored on a secure digital card mounted on the Arduino board which served as the base station. Experimental (case study) results are obtained from the implemented prototype by taking the readings of the sensors stored on the secure digital card under various conditions and numerous results were collected to demonstrate the efficiency and flexibility of the proposed approach. The proposed approach, will assist the smart-home owners to be kept abreast of their environmental condition and equally know what changes would likely to happen. The implemented prototype can be deployed in smart-homes, remote monitoring and healthcare applications.

Keywords: Sensor network (SN), Data acquisition system (DAQ), Performance evaluation, Smart-homes, Light dependent resistor (LDR) sensor, Digital-output relative humidity and temperature (DHT22) sensor, Secure digital (SD) card.

1. Introduction

This study considers the design of a low-cost and flexible sensor network architecture for data acquisition system (DAQ), and provide a performance evaluation of the proposed system. The performance evaluation was based on three parameters, namely, Temperature, Humidity and Light. The readings of these parameters are stored as a text file in a media memory card (SD Card) and a real time clock will

display date and time those parameters are sensed. The sensors with such capabilities are the light dependent resistor (LDR) and digital-output relative humidity and temperature (DHT22) sensors. DHT22 sensor senses both temperature and humidity, while the light dependent resistor-sensor, senses light (Lumina). These components are soldered on a Vero Board together with other digital components that made up the circuit. The fabricated device, is powered by battery to enable the sensors to work perfectly.

The data acquisition systems have emerged over some years from electromechanical recorders with few channels to electronic devices possessing the capabilities of measuring hundreds of parameters simultaneously. The most commonly used data acquisition systems make use of magnetic tape and recorders to record the signals. However, with the advent of new technology, the amount of data and the speed and time of collection increases dramatically. Therefore, there is the need to have a sophisticated device that can measure environmental parameters in real-time for making an informed decision. The computer-based data acquisition system, should possess the capabilities of recording extremely accurate, repeatable, and reliable and error free data, based on the design specifications and consideration [1].

In order to achieve these design specifications and considerations, the data acquisition system should include: selecting the correct sensors for the target application; the choice of proper wire and shielded cable; signal capturing in proper magnitude; signal and frequency ranging; proper grounding and shielding to avoid loops. In addition, the choice of correct impedance and double ended differential inputs is essential. The smart environment in which the device will be used should also be considered, especially for extremes of ambient temperature, humidity and light Lumina [2]. Therefore, the major goal of this research paper is to notify the smart-home users of the changes in the environmental parameters for informed decision making and the most needed recommended practices for smart cities.

The state-of-the-art sensor fusion technique in embedded mobile devices was provided by the authors in [3]. The approach is aimed to assist the mobile device users to identify their daily activities using mobile phones. The sensor fusion techniques are used to aggregate data collected from several sensors to enhance reliability in identifying different activities of the mobile phone users. In this regard, the mobile devices to monitor the user's activities have certain drawbacks, these include: low memory; low battery life and low processing capabilities. And this affects most sensor fusion techniques.

A static calibration and analysis of the Velodyne HDL-64E S2 scanning LiDAR system was demonstrated by the author's work in [4]. The work provided a mathematical model for measurements of the HDL-64E S2 scanner. In order to provide an optimal solution for the laser's internal calibration parameters, a planar feature based least squares adjustment method was demonstrated in a minimally constrained network. The proposed approach, provided a threefold enhancement in the planar misclosure residual over the standard factory calibration model.

The study of parameter selection for data sampling frequency and segmentation techniques and their effect on classification accuracy was studied. The study provided the empirical investigation of different data sampling rates, segmentation techniques and

segmentation window sizes and how they affect the accuracy of activity of daily living event classification. In addition, the study presents the effect of computational load for two different accelerometer-sensor datasets [5].

Advances in heterogeneous communication technologies have enabled sensors to be used in smart cities, things or objects interact with each other while ensuring good network connectivity. However, the existing technologies cannot provide an efficient data acquisition mechanism for flawless and error prone connectivity in smart cities due to the presence of many sensing devices which generates several problems [6-8].

A low-cost microcontroller-based data acquisition device was provided by the authors in [9]. The design consists of a configurable microcontroller-based device with an embedded universal serial bus (USB) transceiver, and a 12-bit analogue-to-digital converter. The embedded DAQ device, is preloaded with a firmware program that allows easy data acquisition and generation of analogue and digital signals. The device, also has the capability of data transfer between the device and the application program running on a personal computer through the use of universal serial bus.

The monitoring of cultural heritage in the context of smart cities was provided by the authors in [10]. The idea is to perform future comparative studies and upload the gathered information into the cloud that will be useful for the conservation of other heritage sites.

The study of the side effect of heterogeneous DAQ hardware was carried out by the authors in [11]. The major challenge is the lack of an accurate synchronization between samples captured by each device. A low-cost hardware modular DAQ architecture consisting of a baseboard and a set of substitutable modules was presented. However, the system is not efficient enough to solve the presence DAQ requirement. Therefore, a design, implementation and performance evaluation of wireless sensor networks for data acquisition system is very essential.

The fundamental objectives of this study are: low-cost architecture, time saving; flexibility of sensor nodes; quick access to data; accuracy; reliability; data integrity, and ease of deployment.

This study will be of immense importance not just to those who use sensor networks for data acquisition (smart-home owners) but also to those who in one way or the other, the result will play a key role in their livelihood. The implemented prototype will go a long way in making a performance evaluation of data acquisition system through sensor networks for monitoring temperature, humidity and light in smart-homes much easier.

The rest of the paper is organized as follows: Section 2 presents the related literature; Section 3 discusses system architecture and design methodology; Section 4 discusses the system simulation methodology; Section 5 discusses

experimental results, case study and performance evaluation; Section 6 provides concluding remarks and plans for future enhancements.

2. Related Work

The work of the authors in [1] discusses the state-of-the-art sensor fusion technique in embedded mobile devices. This approach was aimed to assist the mobile device users to identify their daily activities using mobile phones. The sensor fusion techniques are used to aggregate data collected from several sensors to enhance reliability in identifying different activities of the mobile phone users. Though, the mobile devices to monitor the user's activities have certain drawbacks, these include: low memory, low battery life and low processing capabilities. And this affects most sensor fusion techniques. The author's objective is to present an overview of the state-of-the-art to identify instances of sensor data fusion techniques that are used in mobile devices to track the daily activities of mobile phone users.

In the research work by the authors in [2], a static calibration and analysis of the Velodyne HDL-64E S2 scanning LiDAR system was demonstrated. The work provided a mathematical model for measurements of the HDL-64E S2 scanner. In order to provide an optimal solution for the laser's internal calibration parameters, a planar feature based least squares adjustment method was provided in a minimally constrained network. The work provided the results of the adjustment along with a detailed evaluation of the adjustment residuals. The proposed approach, provided a threefold enhancement in the planar misclosure residual RMSE over the standard factory calibration model. Furthermore, the measurements from the scanner indicated that unmodelled distortions may still be existed in the range measurement. Nevertheless, despite the presence of measurement distortions in the measurements, the whole precision of the adjusted laser scanner data proved to be a practical choice for high accuracy mobile scanning applications.

The authors in [3] study the parameter selection for data sampling frequency and segmentation techniques and their effect on classification accuracy. The authors presented the empirical investigation of different data sampling rates, segmentation techniques and segmentation window sizes and how they affect the accuracy of the activity of daily living. In addition, how they affect the event classification and computational load for two different accelerometer sensor datasets. The authors presented results and recommendations for the choice of the best combination of parameters that are identified based on the equivalent Pareto curve.

The work of the authors in [4] provided a low-cost microcontroller-based data acquisition device. The major components of the device consist of a configurable microcontroller-based device with an embedded USB transceiver and a 12-bit analogue-to-

digital converter. The embedded DAQ device, is preloaded with a firmware program that allows easy data acquisition and generation of analogue and digital signals. It also has the capabilities of data transfer between the device and the application program running on a personal computer through the use of universal serial bus. Furthermore, the authors presented the LabVIEW drivers for the fabricated device.

The authors in [5] propose monitoring of cultural heritage in the context of smart cities. The idea is to perform future comparative studies and upload the gathered information into the cloud that will be useful for the conservation of other heritage sites. The authors presented the development of an economical and appropriate data acquisition system which integrate wired and wireless communication, and third-party hardware tools for increased versatility of the designed system. The proposed device provided the capability of monitoring a complex network of points with high sampling frequency. The device used a wired sensor in a 1-wire bus and a wireless centralized data recording system and monitoring of physical parameters. Furthermore, it is envisaged that the device, will possess the future capability of attaching an alarm system or sending data over the Internet. The development of three board design and over five thousand algorithm lines of codes, demonstrated the efficiency of the proposed system.

The work of the authors in [6], study the side effect of heterogeneous DAQ hardware. The major problem is the lack of an accurate synchronization between samples captured by each device. In order to provide a solution to this problem, the authors proposed a low-cost hardware modular DAQ architecture consisting of a baseboard and a set of substitutable modules. The main objective is the ability to sample all data sources at predictable, fixed sampling frequencies, with a reduced synchronization mismatch of less than one second between heterogeneous signal sources. Experimental results were presented, demonstrating vibration spectrum analyses from piezoelectric accelerometers and a spectrum of quadrature encoder signals. Other approaches are given by the work of the respective authors in the literature [12-17].

3. System Architecture and Design

Fig. 1 illustrates the block diagram of a real-time device monitoring system. Once connection is established, the DHT22 and a light dependent resistor (LDR) sensors will verify the established connection and start reading the temperature, humidity and light Lumina, and the processed data or information is displayed by the LCD through the user interface window. Then, a real-time clock (RTC) module is accessed through I2C interface to obtain the current date and time. The SD card is accessed via SPI interface and a new data log file is created. If the file already exists, the new data will be written with its new date and time stamp beneath the existed data

inside the file. The two sensors will automatically start taking measurements of the indicated parameters, temperature, humidity and light [15-18].

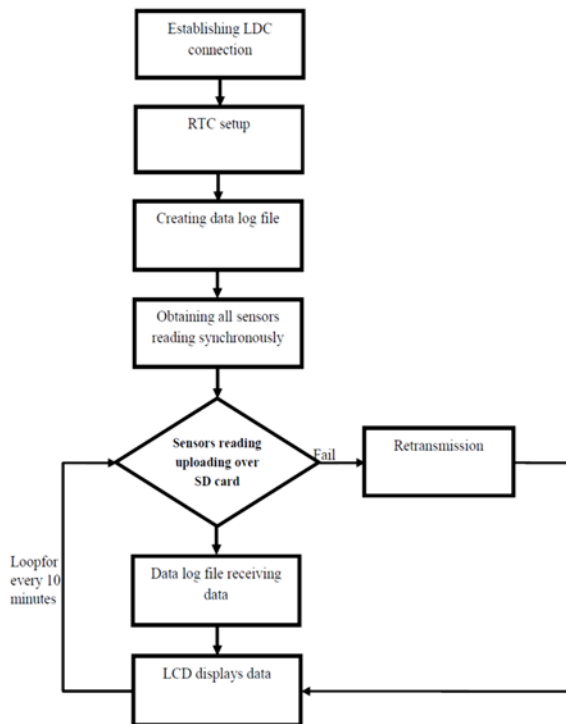

Fig. 1. Real time device monitoring system flow.

Fig. 2 shows the system architecture. The architecture consists of three input parameters, namely, temperature, humidity and light. The real-time clock module provides an input real-time clock signal to the ADC. The output of the ADC is transmitted to the microcontroller unit for processing. The microcontroller will then, process the sensor data and transmits the processed data to the LCD for display and to the secure data (SD) card for storage. The electrically erasable programmable read-only memory (EEPROM) serves as an on-chip memory for the microcontroller. All electronics operations are controlled by a single microcontroller unit, which is programmed based on how other peripherals components of the system will behave.

This device architecture, consists of two sensors; namely, temperature and humidity (integrated into a single module), and Light (LDR). The temperature and humidity sensors are responsible for detecting ambient environmental changes [19-21].

The LDR sensor is used to detect the Lumina (brightness) of light. The sensor's data readings are registered in the microcontroller unit along with date and time stamp synchronously. The data is then be uploaded over into the data log file monitoring database to provide the smart-home users with the real time data [22-23].

Fig. 3 illustrates the fabricated device prototype. The casing fabrication was done with plastic, and carefully engineered. The casing is portable like a

small box which can be hand held and can be carried about easily.

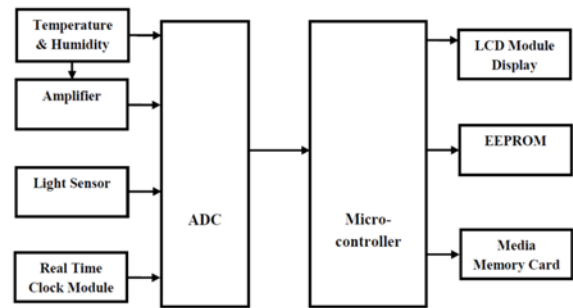

Fig. 2. System Architecture.



Fig. 3. The fabricated device's prototype.

4. System Simulation

Herein, the procedure to simulate the sensor network for data acquisition system is provided. In order to demonstrate the concepts of the data acquisition using simulation methodology, a complete SN model was built as shown in Fig. 4 and Fig. 5. This network consists of three sensors serving as communication nodes (i.e. slave nodes) sending their measured data samples to a master node (SD card). Other components of the system are: real time clock; media memory card (MMC); liquid crystal display, virtual terminal and many other devices that are integrated to form the complete system. In addition, two power supply sources are provided [24].

The design of the sensor network for the data acquisition system is simulated using the Proteus 8.5 design suite, Arduino Uno integrated development environment (IDE), and embedded C programming language. Proteus 8.5 professional is an efficient tool and a high-performance design environment for simulating technical computing. The package integrates computation and virtual representation of the systematic operation of the system and shows how the prototype system components will operate. Arduino as the development board provides a user-friendly design environment IDE where embedded C source codes can be written, verified, and uploaded to the microcontroller unit [25].

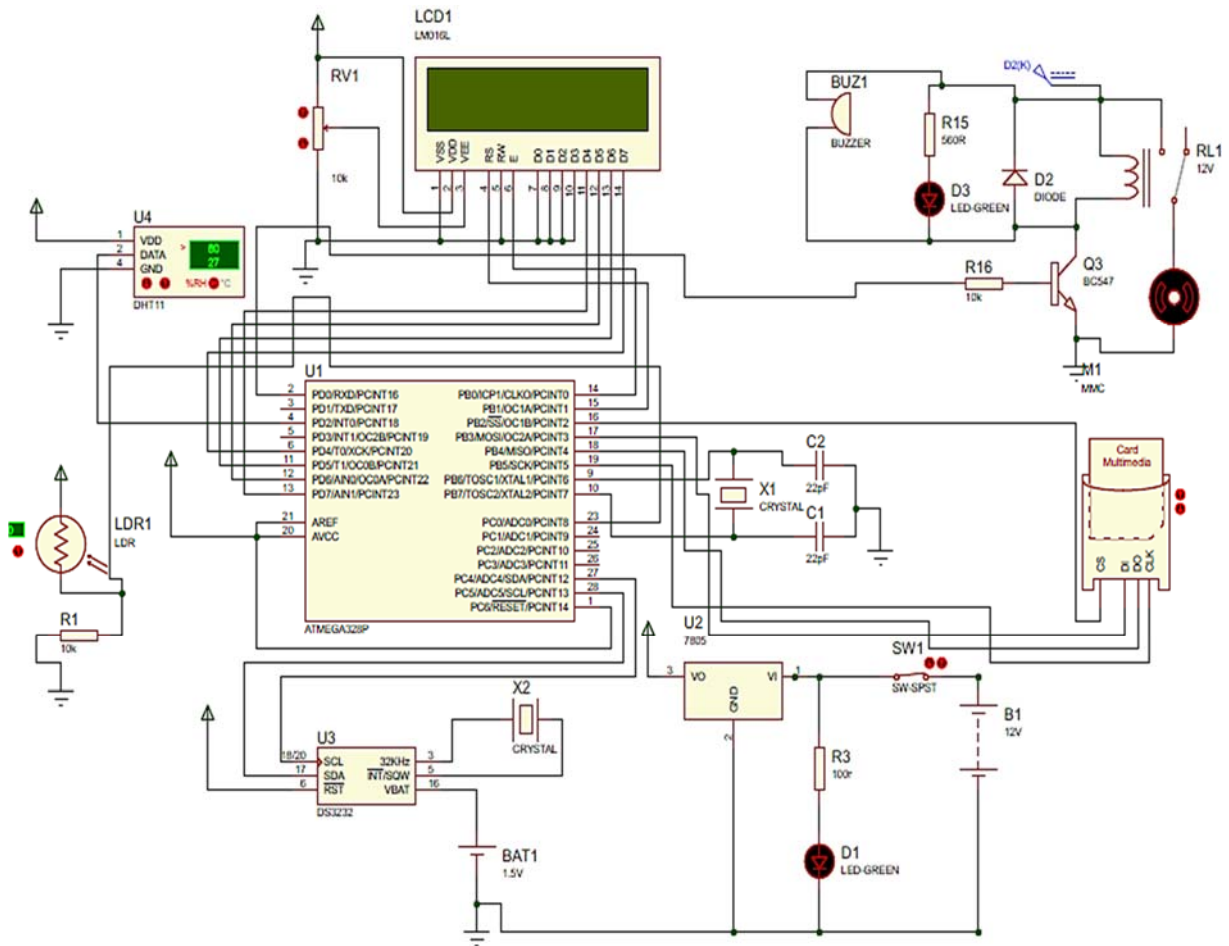

Fig. 4. The system simulation.

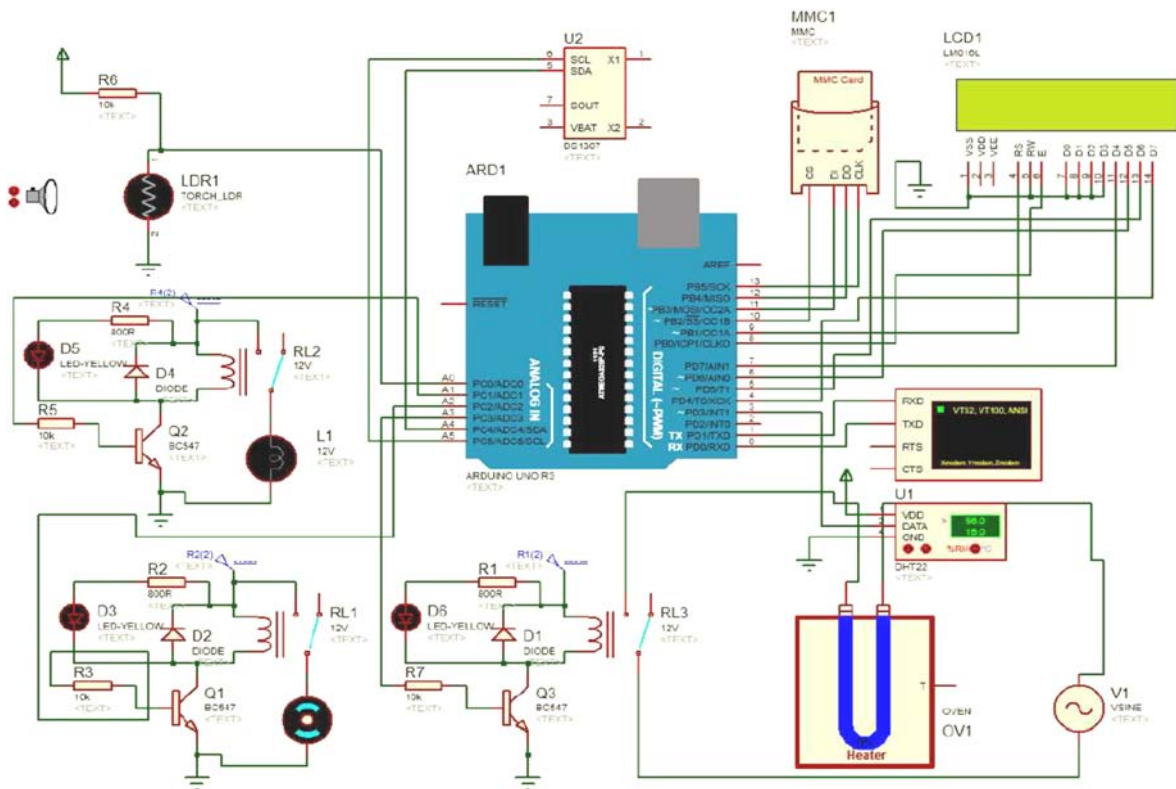

Fig. 5. The system simulation.

The design of the sensor network makes use of an Arduino board. Arduino is an open-source electronics platform that provides easy hardware / software co-design tools for designing embedded applications. Embedded C programming language is suitable for the design of embedded systems and sensor components. The codes written in embedded C language allow the circuit or devices to achieve their optimal performance. In addition, it has a failure rate less than one percent when developed to interact with the hardware components. These features of the embedded C language are employed and used to provide a low-cost, flexible and highly efficient DAQ system for measuring ambient environmental changes for smart-home owners [26].

5. Experimental Results (Case Study)

The experiment was conducted using the fabricated device prototype. A case study of a smart-

home was chosen and the device was run for 52 hours and 30 minutes continuously. The three sensor measurements are captured, stored and processed.

5.1. Sensor Data Logging

Fig. 6 and Fig. 7, illustrates the data logged by the three sensors. Each sensor sends its captured data to the microcontroller. The microcontroller, processes the data and sends it to the receiver (SD card) base station and to the LCD display unit for user information. In addition, the processed sensor data is sent to a serial terminal emulator and logged to a data file. The saved data can be opened with any text editor for further analysis. Here data logging of temperature, light and humidity with their appending date and time is shown in a serial terminal emulator as shown in Fig. 6 and Fig. 7.

```

Data Acquisition System using Sensor Network for Smart-home Users
-----Sensors Data Logging-----
Date          Time          temp (C)      Light (Lum)   Humidity (%)
-----
2017/9/19    8:8:5         27.50         5336.3        62.0
2017/9/19    8:8:13        27.60         5775.7        61.5
2017/9/19    8:8:22        27.90         5783.9        58.6
2017/9/19    8:8:30        28.50         5515.3        56.7
2017/9/19    8:8:38        28.40         5564.1        55.5
2017/9/19    8:8:47        28.20         5572.3        54.7
2017/9/19    8:8:55        28.10         5458.3        54.6
2017/9/19    8:10:0        29.30         5783.9        51.1
2017/9/19    8:10:8        29.40         5783.9        50.3
2017/9/19    8:10:17       29.60         5775.7        49.7
2017/9/19    8:10:25       29.80         5783.9        49.0
2017/9/19    8:10:33       29.90         5783.9        48.4
2017/9/19    8:10:42       30.10         5783.9        47.8
2017/9/19    8:10:50       30.20         5783.9        46.8
2017/9/19    8:10:58       30.40         5783.9        45.8

```

Fig. 6. Data logging of temperature, light and humidity sensors (scene 1).

```

Date          Time          temp (C)      Light (Lum)   Humidity (%)
-----
2017/9/19    8:12:4        31.60         5783.9        41.9
2017/9/19    8:12:12       31.60         5783.9        41.4
2017/9/19    8:12:20       31.80         5783.9        40.9
2017/9/19    8:12:29       31.90         5783.9        40.4
2017/9/19    8:12:37       32.10         5783.9        40.6
2017/9/19    8:12:45       32.20         5783.9        40.0
2017/9/19    8:12:54       32.30         5783.9        39.7
2017/9/19    8:14:5        33.30         5783.9        37.6
2017/9/19    8:14:13       33.30         5783.9        37.3
2017/9/19    8:14:22       33.50         5783.9        36.9
2017/9/19    8:14:30       33.50         5783.9        36.4
2017/9/19    8:14:38       33.60         5783.9        36.1
2017/9/19    8:14:47       33.70         5783.9        35.7
2017/9/19    8:14:55       33.80         5783.9        35.6
2017/9/19    8:16:0        34.50         5783.9        34.1
2017/9/19    8:16:8        34.50         5783.9        34.0
2017/9/19    8:16:17       34.60         5783.9        33.8
2017/9/19    8:16:25       34.80         5783.9        33.5
2017/9/19    8:16:33       34.80         5783.9        33.1
2017/9/19    8:16:42       34.90         5783.9        32.9
2017/9/19    8:16:50       34.90         5783.9        32.7
2017/9/19    8:16:58       35.00         5783.9        32.8

```

Fig. 7. Data logging of temperature, light and humidity sensors (scene 2).

5.2. Performance Evaluation

The performance evaluation of the three sensor readings is illustrated in Fig. 8 to Fig. 10. Fig. 8 illustrates the temperature sensor readings against time of a smart-home as a case study. There are three scenarios namely, morning, afternoon and night as indicated in the figure. And each scenario is boarded with a vertical gold, black and thick red dotted lines for easy understanding.

The temperature reading samples were taken once for every 30 minutes. The measurements ran for over 104 samples, and the device had been running for 52 hours and 30 minutes continuously. The temperature reading shows 37 °C max and 25 °C min, while the temperature during the morning of the first day, obviously dropped by 12 °C, and constantly

swings between 27 °C and 37 °C during the morning and drastically dropped during the night.

Fig. 9 shows the light sensing result, that is, the light sensor's reading is very high during the daylight (morning) and very low at night. During the daytime, the Lumina varies depending on the atmospheric weather condition either cloudy or sunny. This variation ranges between 3480 to 5710 Lumina, and we can also observe a significant drop in the light sensor's reading, especially, at sunsets (night) to be between 1609 to 1999 Lumina. However, we can observe that where the Lumina reading goes low during the daytime, it shows that the doors and the windows of the smart-home were closed / locked by the owners. Similarly, where the Lumina reading goes up during the night time, it is an indication that there was a light flashing either from electric bulb or nearby automobile cars.

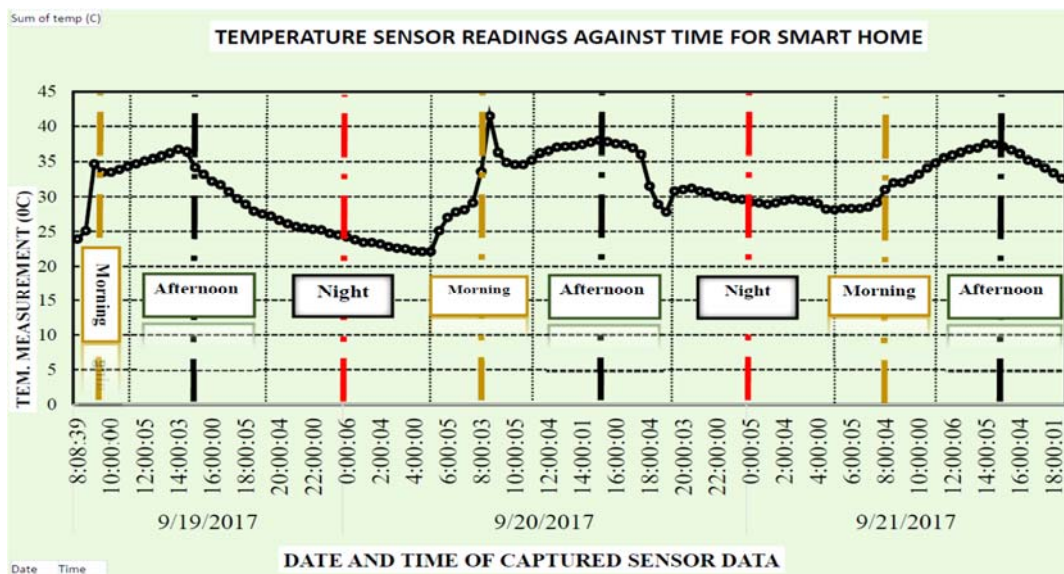

Fig. 8. Temperature sensor readings against time for smart-home.

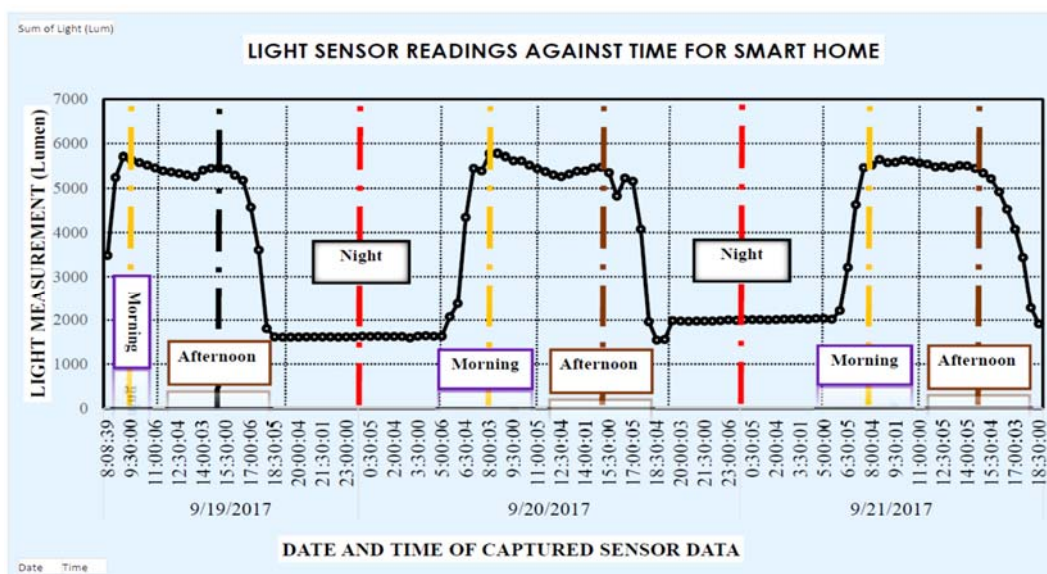

Fig. 9. Light sensor readings against time for smart-home.

Fig. 10 illustrates the humidity sensor readings for smart-homes. As can be observed, the humidity readings are higher during the night most especially the day that it rained and lower during a normal day. It can also be observed that during the night, the humidity sensor measurements varies in the ranges of 44 to 85. However, humidity measurements dropped to 22 and varies in the ranges of 22 to 85.

These results demonstrate the efficiency and reliability of the fabricated device prototype and its

application to smart-homes. The device will be of immense importance to the smart-home owners to be kept abreast of their environmental condition and equally know what changes are likely to happen and when. The performance of the proposed system is reliable in terms of captured data, speed, accuracy, integrity and capacity in its storage as demonstrated in the experimental results. The fabricated device prototype can be deployed in smart-homes, remote monitoring and healthcare application.

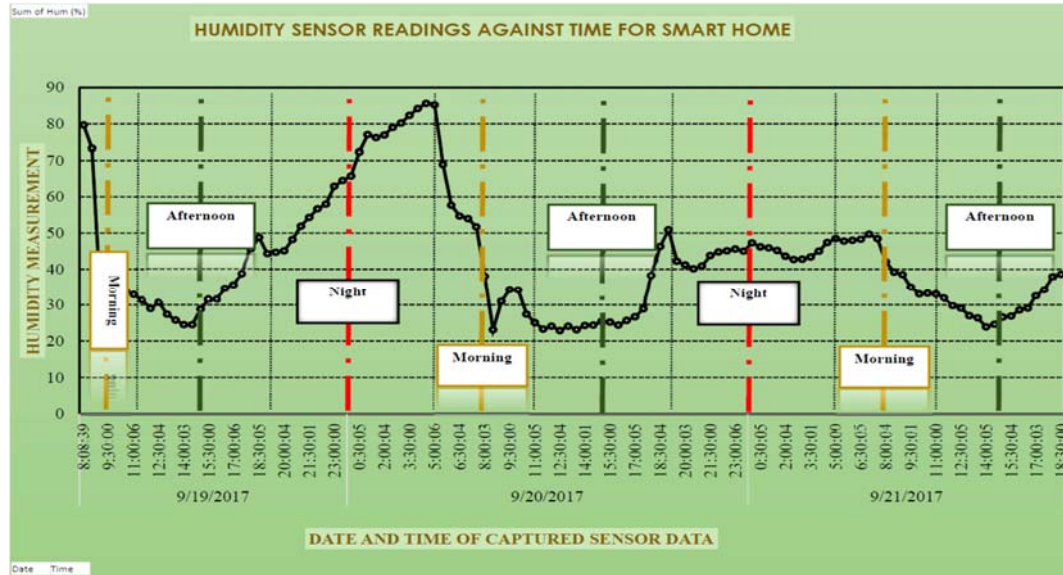

Fig. 10. Humidity sensor readings against time for smart-home.

6. Conclusion and Future Work

This research paper used the capabilities of two sensors with three parameters for the data acquisition system. The sensors include: DHT22 used for measuring temperature and humidity, and a light dependent resistor (LDR) used for measuring light Lumina. The real time clock (RTC) module was used for capturing date and time stamp of the sensed parameters to record their actual readings. The media memory card (MMC) was used as the main base station for the storage of the sensor data. The methodology used in this paper is the rigorous performance analysis of the data stored on SD Card (base station). The recording of the sensor's measurement into the SD card was done in the interval of 30 minutes. The sensor's reading stored on the SD card with date and time stamped for the three parameters are used to plot the graphs of the three parameters versus time. This approach will help the smart-home owners to be kept abreast of their environmental condition and equally know what changes are likely to happen and when. The performance of the system is reliable in terms of captured data, speed, accuracy, integrity and capacity in its storage. Experimental results from the fabricated (device) prototype, demonstrates the efficiency and reliability of the proposed approach. Overall, the

system can be deployed in smart homes, remote monitoring and healthcare applications.

The future work will consider the integration of a WiFi module to enable transmission, visualization and storage of sensor data over the internet. The use of the field programmable gate array (FPGA) and system-on-chip (SoC) will be considered to provide flexible, programmable and high-performance capabilities. Smart-home users can access the information regarding their environment from remote locations.

Acknowledgements

Special thanks are owed to Dr. Maria Liz Crespo of the Abdussalam International Centre for Theoretical Physics (ICTP), Trieste, Italy and Dr. Iain Darby of the International Atomic Energy Agency (IAEA), Vienna, Austria, for the ICTP workshop / seminar smr 3143, "Joint ICTP-IAEA School on Zynq-7000 SoC and its Applications for Nuclear and Related Instrumentation", Aug – Sep, 2017, Trieste, Italy.

References

- [1]. Measurement computing corporation, Data Acquisition hand book: A Reference for DAQ and

- Analog and Digital Signal Conditioning, Third Edition, Vol. 508, 2012, pp. 946-5100.
- [2]. I. Yaqoob, I. A. T. Hashem, Y. Mehmood, A. Gani, S. Mokhtar, S. Guizani, Enabling Communication Technologies for Smart Cities, *IEEE Communications Magazine*, Vol. 55, No. 1, 2017, pp. 114-122.
 - [3]. Ivan Miguel Pires, M. G. Nuno, N. Pombo, F. Flórez-Revuelta, From Data Acquisition to Data Fusion: A Comprehensive Review and a Roadmap for the Identification of Activities of Daily Living Using Mobile Devices, *Sensors*, Vol. 16, Issue 2, 2016, pp. 2-27.
 - [4]. C. Glennie, D. D. Lichti, Static Calibration and Analysis of the Velodyne HDL-64E S2 for High Accuracy Mobile Scanning, *Remote Sensing*, Vol. 2, 2010, pp. 1610-1624.
 - [5]. D. Bersch Sebastian, D. Azzi, R. Khusainov, I. E. Achumba, J. Ries, Sensor Data Acquisition and Processing Parameters for Human Activity Classification, *Sensors*, Vol. 14, Issue 3, 2014, pp. 4241-4270.
 - [6]. R. Fernandes, *et al.*, Flexible Wireless Sensor Network for Smart Lighting Applications, in *Proceedings of the IEEE Int'l. Conf. Instrumentation and Measurement Technology*, 2014, pp. 434-39.
 - [7]. D. I. Tapia, J. B. Rodridiguez, J. M. Corchado, O. Garcia, Wireless Sensor Networks for data acquisition and information fusion: A case study, in *Proceedings of the 13th International Conference on Information Fusion*, 2010.
 - [8]. R. R. Brooks, Wireless Sensor Networks: Architecture and Protocols, *International Journal of Distributed Sensor Networks*, Vol. 4, Issue 3, 2008, pp. 286-286.
 - [9]. D. Hercog, B. Gergič, A Flexible Microcontroller-Based Data Acquisition Device, *Sensors*, Vol. 14, Issue 6, 2014, pp. 9755-9775.
 - [10]. G. D. Fernando-Juan, B. Esteban, P. Merello, Design of a Hybrid (Wired/Wireless) Acquisition Data System for Monitoring of Cultural Heritage Physical Parameters in Smart Cities, *Sensors*, Vol. 15, Issue 4, 2015, pp. 7246-7266.
 - [11]. J. L. Blanco-Claraco, J. López-Martínez, J. L. Torres-Moreno, A. Giménez-Fernández, A Low-Cost Modular Platform for Heterogeneous Data Acquisition with Accurate Interchannel Synchronization, *Sensors*, Vol. 15, Issue 10, 2015, pp. 27374-27392.
 - [12]. N. Ling, D. Mei-Xia, Design of a Remote Data Monitoring System based on Sensor Network, *International Journal of Smart Home*, Vol. 9, Issue 5, 2015, pp. 23-30.
 - [13]. H. Chen, L. Cui, C. Huang, H. Zhu, EasiSim: A Scalable Simulator for Wireless Sensor Networks, *Wireless Sensor Network*, Vol. 1, Issue 5, 2009, pp. 467-474.
 - [14]. D. Yan, Z. Dan, ZigBee-based Smart Home system design, in *Proceedings of the 3rd International Conference on Advanced Computer Theory and Engineering (ICACTE)*, 2010.
 - [15]. M. Xu, L. Ma, X. Feng, L. M. Shao, Design and Implementation of a Wireless Sensor Network for Smart Homes (PDF Download Available). Retrieved February 20, 2018, (https://www.researchgate.net/publication/47796829_Design_and_Implementation_of_a_Wireless_Sensor_Network_for_Smart_Homes).
 - [16]. M. Moghavvemi, S. Tan, A reliable and economically feasible remote sensing system for temperature and relative humidity measurement. *Sensors and Actuators, A: Physical*, Vol. 117, Issue 2, 2005, pp. 181-185.
 - [17]. K. Montgomery, K. Chiang, A New Paradigm for Integrated Environmental Monitoring, in *Proceedings of the ACM International Conference Proceeding Series*, 2010.
 - [18]. S. Abba, J. Lee, FPGA-Based Design of an Intelligent On-Chip Sensor Network Monitoring and Control Using Dynamically Reconfigurable Autonomous Sensor Agents, *Int. Journal of Distributed Sensor Networks*, Vol. 2016, Article ID 4246596, 29 pages.
 - [19]. L. Grzegorz, A. Rieger, M. Blumendorf, S. Albayrak, A 3-Layer Architecture for Smart Environment Models, A model-based approach, Labor Technische University Berlin, Germany, in *Proceedings of the 8th IEEE International Conference on Pervasive Computing and Communications Workshops (PERCOM Workshops)*, 2010.
 - [20]. C. Andrew, Internet of things (IoT) design considerations for embedded connected devices, *White paper, Embedded Software*, Mentor Graphics Corporation, TECH12120-w MGC 05-14, 2014, pp. 1-6.
 - [21]. M. P. José, O. A. Postolache, P. S. Girão, Analog to Digital Conversion Methods for Smart Sensing Systems, *Advances in Measurement Systems*, Vol. 56, Issue 1, 2010, pp. 576-592.
 - [22]. S. Abba, J. Lee, An Autonomous Self-Aware and Adaptive Fault Tolerant Routing Technique for Wireless Sensor Networks, *Sensors* 2015, Vol. 15, Issue 8, 2015, pp. 20316-20354.
 - [23]. M. T. Lazarescu, Design and Field Test of a WSN Platform Prototype for Long-Term Environmental Monitoring, *Sensors*, 2015, Vol. 15, Issue 4, pp. 9481-9518.
 - [24]. S. Abba, I. M. Nyam, Design, implementation and performance evaluation of wireless sensor networks for data acquisition system (A case study of smart homes), in *Proceedings of the 1st International Conference on Microelectronic Devices and Technologies (MicDAT'2018)*, 20-22 June 2018, Barcelona, Spain, Vol. 34, 2018, pp. 101-107.
 - [25]. Labcenter Electronics Ltd. Proteus Design Suite 8.5 Professional, available at: www.labcenter.com (accessed on 10 February 2018).
 - [26]. Arduino Integrated Development Design Environment, available at: www.arduino.cc (accessed on 8 February 2018).

