

ISSN 1726-5479

SENSORS & TRANSDUCERS

12^{vol. 111}/09



Sensor Market Trends

International Frequency Sensor Association Publishing



Editors-in-Chief: professor Sergey Y. Yurish,
Phone: +34 696067716, fax: +34 93 4011989, e-mail: editor@sensorsportal.com

Editors for Western Europe

Meijer, Gerard C.M., Delft University of Technology, The Netherlands
Ferrari, Vittorio, Università di Brescia, Italy

Editor South America

Costa-Felix, Rodrigo, Inmetro, Brazil

Editor for Eastern Europe

Sachenko, Anatoly, Ternopil State Economic University, Ukraine

Editors for North America

Datskos, Panos G., Oak Ridge National Laboratory, USA
Fabien, J. Josse, Marquette University, USA
Katz, Evgeny, Clarkson University, USA

Editor for Asia

Ohyama, Shinji, Tokyo Institute of Technology, Japan

Editor for Asia-Pacific

Mukhopadhyay, Subhas, Massey University, New Zealand

Editorial Advisory Board

- Abdul Rahim, Ruzairi**, Universiti Teknologi, Malaysia
Ahmad, Mohd Noor, Northern University of Engineering, Malaysia
Annamalai, Karthigeyan, National Institute of Advanced Industrial Science and Technology, Japan
Arcega, Francisco, University of Zaragoza, Spain
Arguel, Philippe, CNRS, France
Ahn, Jae-Pyoung, Korea Institute of Science and Technology, Korea
Arndt, Michael, Robert Bosch GmbH, Germany
Ascoli, Giorgio, George Mason University, USA
Atalay, Selcuk, Inonu University, Turkey
Atghiaee, Ahmad, University of Tehran, Iran
Augutis, Vygantas, Kaunas University of Technology, Lithuania
Avachit, Patil Lalchand, North Maharashtra University, India
Ayesh, Aladdin, De Montfort University, UK
Bahreyni, Behraad, University of Manitoba, Canada
Baliga, Shankar, B., General Motors Transnational, USA
Baoxian, Ye, Zhengzhou University, China
Barford, Lee, Agilent Laboratories, USA
Barlingay, Ravindra, RF Arrays Systems, India
Basu, Sukumar, Jadavpur University, India
Beck, Stephen, University of Sheffield, UK
Ben Bouzid, Sihem, Institut National de Recherche Scientifique, Tunisia
Benachaiba, Chellali, Universitaire de Bechar, Algeria
Binnie, T. David, Napier University, UK
Bischoff, Gerlinde, Inst. Analytical Chemistry, Germany
Bodas, Dhananjay, IMTEK, Germany
Borges Carval, Nuno, Universidade de Aveiro, Portugal
Bousbia-Salah, Mounir, University of Annaba, Algeria
Bouvet, Marcel, CNRS – UPMC, France
Brudzewski, Kazimierz, Warsaw University of Technology, Poland
Cai, Chenxin, Nanjing Normal University, China
Cai, Qingyun, Hunan University, China
Campanella, Luigi, University La Sapienza, Italy
Carvalho, Vitor, Minho University, Portugal
Cecelja, Franjo, Brunel University, London, UK
Cerda Belmonte, Judith, Imperial College London, UK
Chakrabarty, Chandan Kumar, Universiti Tenaga Nasional, Malaysia
Chakravorty, Dipankar, Association for the Cultivation of Science, India
Changhai, Ru, Harbin Engineering University, China
Chaudhari, Gajanan, Shri Shivaji Science College, India
Chavali, Murthy, VIT University, Tamil Nadu, India
Chen, Jiming, Zhejiang University, China
Chen, Rongshun, National Tsing Hua University, Taiwan
Cheng, Kuo-Sheng, National Cheng Kung University, Taiwan
Chiang, Jeffrey (Cheng-Ta), Industrial Technol. Research Institute, Taiwan
Chiriac, Horia, National Institute of Research and Development, Romania
Chowdhuri, Arijit, University of Delhi, India
Chung, Wen-Yaw, Chung Yuan Christian University, Taiwan
Corres, Jesus, Universidad Publica de Navarra, Spain
Cortes, Camilo A., Universidad Nacional de Colombia, Colombia
Courtois, Christian, Universite de Valenciennes, France
Cusano, Andrea, University of Sannio, Italy
D'Amico, Arnaldo, Università di Tor Vergata, Italy
De Stefano, Luca, Institute for Microelectronics and Microsystem, Italy
Deshmukh, Kiran, Shri Shivaji Mahavidyalaya, Barshi, India
Dickert, Franz L., Vienna University, Austria
Dieguez, Angel, University of Barcelona, Spain
Dimitropoulos, Panos, University of Thessaly, Greece
Ding, Jianning, Jiangsu Polytechnic University, China
Djordjevic, Alexandar, City University of Hong Kong, Hong Kong
Donato, Nicola, University of Messina, Italy
Donato, Patricio, Universidad de Mar del Plata, Argentina
Dong, Feng, Tianjin University, China
Drljaca, Predrag, Instersema Sensoric SA, Switzerland
Dubey, Venketesh, Bournemouth University, UK
Enderle, Stefan, Univ. of Ulm and KTB Mechatronics GmbH, Germany
Erdem, Gursan K. Arzum, Ege University, Turkey
Erkmen, Aydan M., Middle East Technical University, Turkey
Estelle, Patrice, Insa Rennes, France
Estrada, Horacio, University of North Carolina, USA
Faiz, Adil, INSA Lyon, France
Fericean, Sorin, Balluff GmbH, Germany
Fernandes, Joana M., University of Porto, Portugal
Francioso, Luca, CNR-IMM Institute for Microelectronics and Microsystems, Italy
Francis, Laurent, University Catholique de Louvain, Belgium
Fu, Weiling, South-Western Hospital, Chongqing, China
Gaura, Elena, Coventry University, UK
Geng, Yanfeng, China University of Petroleum, China
Gole, James, Georgia Institute of Technology, USA
Gong, Hao, National University of Singapore, Singapore
Gonzalez de la Rosa, Juan Jose, University of Cadiz, Spain
Granel, Annette, Goteborg University, Sweden
Graff, Mason, The University of Texas at Arlington, USA
Guan, Shan, Eastman Kodak, USA
Guillet, Bruno, University of Caen, France
Guo, Zhen, New Jersey Institute of Technology, USA
Gupta, Narendra Kumar, Napier University, UK
Hadjiloucas, Sillas, The University of Reading, UK
Haider, Mohammad R., Sonoma State University, USA
Hashsham, Syed, Michigan State University, USA
Hasni, Abdelhafid, Bechar University, Algeria
Hernandez, Alvaro, University of Alcalá, Spain
Hernandez, Wilmar, Universidad Politecnica de Madrid, Spain
Homentcovschi, Dorel, SUNY Binghamton, USA
Horstman, Tom, U.S. Automation Group, LLC, USA
Hsiai, Tzung (John), University of Southern California, USA
Huang, Jeng-Sheng, Chung Yuan Christian University, Taiwan
Huang, Star, National Tsing Hua University, Taiwan
Huang, Wei, PSG Design Center, USA
Hui, David, University of New Orleans, USA
Jaffrezic-Renault, Nicole, Ecole Centrale de Lyon, France
Jaime Calvo-Galleg, Jaime, Universidad de Salamanca, Spain
James, Daniel, Griffith University, Australia
Janting, Jakob, DELTA Danish Electronics, Denmark
Jiang, Liudi, University of Southampton, UK
Jiang, Wei, University of Virginia, USA
Jiao, Zheng, Shanghai University, China
John, Joachim, IMEC, Belgium
Kalach, Andrew, Voronezh Institute of Ministry of Interior, Russia
Kang, Moonho, Sunmoon University, Korea South
Kaniusas, Eugenijus, Vienna University of Technology, Austria
Katake, Anup, Texas A&M University, USA
Kausel, Wilfried, University of Music, Vienna, Austria
Kavasoglu, Nese, Mugla University, Turkey
Ke, Cathy, Tyndall National Institute, Ireland
Khan, Asif, Aligarh Muslim University, Aligarh, India
Sapozhnikova, Ksenia, D.I.Mendeleyev Institute for Metrology, Russia

Kim, Min Young, Kyungpook National University, Korea South
Ko, Sang Choon, Electronics and Telecommunications Research Institute, Korea South
Kockar, Hakan, Balikesir University, Turkey
Kotulska, Malgorzata, Wroclaw University of Technology, Poland
Kratz, Henrik, Uppsala University, Sweden
Kumar, Arun, University of South Florida, USA
Kumar, Subodh, National Physical Laboratory, India
Kung, Chih-Hsien, Chang-Jung Christian University, Taiwan
Lacnjevac, Caslav, University of Belgrade, Serbia
Lay-Ekuakille, Aime, University of Lecce, Italy
Lee, Jang Myung, Pusan National University, Korea South
Lee, Jun Su, Amkor Technology, Inc. South Korea
Lei, Hua, National Starch and Chemical Company, USA
Li, Genxi, Nanjing University, China
Li, Hui, Shanghai Jiaotong University, China
Li, Xian-Fang, Central South University, China
Liang, Yuanchang, University of Washington, USA
Liawruangrath, Saisunee, Chiang Mai University, Thailand
Liew, Kim Meow, City University of Hong Kong, Hong Kong
Lin, Hermann, National Kaohsiung University, Taiwan
Lin, Paul, Cleveland State University, USA
Linderholm, Pontus, EPFL - Microsystems Laboratory, Switzerland
Liu, Aihua, University of Oklahoma, USA
Liu Changgeng, Louisiana State University, USA
Liu, Cheng-Hsien, National Tsing Hua University, Taiwan
Liu, Songqin, Southeast University, China
Lodeiro, Carlos, University of Vigo, Spain
Lorenzo, Maria Encarnacio, Universidad Autonoma de Madrid, Spain
Lukaszewicz, Jerzy Pawel, Nicholas Copernicus University, Poland
Ma, Zhanfang, Northeast Normal University, China
Majstorovic, Vidosav, University of Belgrade, Serbia
Marquez, Alfredo, Centro de Investigacion en Materiales Avanzados, Mexico
Matay, Ladislav, Slovak Academy of Sciences, Slovakia
Mathur, Prafull, National Physical Laboratory, India
Maurya, D.K., Institute of Materials Research and Engineering, Singapore
Mekid, Samir, University of Manchester, UK
Melnyk, Ivan, Photon Control Inc., Canada
Mendes, Paulo, University of Minho, Portugal
Mennell, Julie, Northumbria University, UK
Mi, Bin, Boston Scientific Corporation, USA
Minas, Graca, University of Minho, Portugal
Moghavvemi, Mahmoud, University of Malaya, Malaysia
Mohammadi, Mohammad-Reza, University of Cambridge, UK
Molina Flores, Esteban, Benemérita Universidad Autónoma de Puebla, Mexico
Moradi, Majid, University of Kerman, Iran
Morello, Rosario, University "Mediterranea" of Reggio Calabria, Italy
Mounir, Ben Ali, University of Sousse, Tunisia
Mulla, Imtiaz Sirajuddin, National Chemical Laboratory, Pune, India
Neelamegam, Periasamy, Sastra Deemed University, India
Neshkova, Milka, Bulgarian Academy of Sciences, Bulgaria
Oberhammer, Joachim, Royal Institute of Technology, Sweden
Ould Lahoucine, Cherif, University of Guelma, Algeria
Pamidighanta, Sayanu, Bharat Electronics Limited (BEL), India
Pan, Jisheng, Institute of Materials Research & Engineering, Singapore
Park, Joon-Shik, Korea Electronics Technology Institute, Korea South
Penza, Michele, ENEA C.R., Italy
Pereira, Jose Miguel, Instituto Politecnico de Setebal, Portugal
Petsev, Dimiter, University of New Mexico, USA
Pogacnik, Lea, University of Ljubljana, Slovenia
Post, Michael, National Research Council, Canada
Prance, Robert, University of Sussex, UK
Prasad, Ambika, Gulbarga University, India
Prateepasen, Asa, Kingmoungut's University of Technology, Thailand
Pullini, Daniele, Centro Ricerche FIAT, Italy
Pumera, Martin, National Institute for Materials Science, Japan
Radhakrishnan, S., National Chemical Laboratory, Pune, India
Rajanna, K., Indian Institute of Science, India
Ramadan, Qasem, Institute of Microelectronics, Singapore
Rao, Basuthkar, Tata Inst. of Fundamental Research, India
Raouf, Kosai, Joseph Fourier University of Grenoble, France
Reig, Candid, University of Valencia, Spain
Restivo, Maria Teresa, University of Porto, Portugal
Robert, Michel, University Henri Poincare, France
Rezazadeh, Ghader, Urmia University, Iran
Royo, Santiago, Universitat Politècnica de Catalunya, Spain
Rodriguez, Angel, Universidad Politécnica de Catalunya, Spain
Rothberg, Steve, Loughborough University, UK
Sadana, Ajit, University of Mississippi, USA
Sadeghian Marnani, Hamed, TU Delft, The Netherlands
Sandacci, Serghei, Sensor Technology Ltd., UK
Saxena, Vibha, Bhabha Atomic Research Centre, Mumbai, India
Schneider, John K., Ultra-Scan Corporation, USA
Seif, Selemani, Alabama A & M University, USA
Seifter, Achim, Los Alamos National Laboratory, USA
Sengupta, Deepak, Advance Bio-Photonics, India
Shearwood, Christopher, Nanyang Technological University, Singapore
Shin, Kyuho, Samsung Advanced Institute of Technology, Korea
Shmaliy, Yuriy, Kharkiv National Univ. of Radio Electronics, Ukraine
Silva Girao, Pedro, Technical University of Lisbon, Portugal
Singh, V. R., National Physical Laboratory, India
Slomovitz, Daniel, UTE, Uruguay
Smith, Martin, Open University, UK
Soleymannpour, Ahmad, Damghan Basic Science University, Iran
Somani, Prakash R., Centre for Materials for Electronics Technol., India
Srinivas, Talabattula, Indian Institute of Science, Bangalore, India
Srivastava, Arvind K., Northwestern University, USA
Stefan-van Staden, Raluca-Ioana, University of Pretoria, South Africa
Sunriddetchka, Sarun, National Electronics and Computer Technology Center, Thailand
Sun, Chengliang, Polytechnic University, Hong-Kong
Sun, Dongming, Jilin University, China
Sun, Junhua, Beijing University of Aeronautics and Astronautics, China
Sun, Zhiqiang, Central South University, China
Suri, C. Raman, Institute of Microbial Technology, India
Sysoev, Victor, Saratov State Technical University, Russia
Szewczyk, Roman, Industrial Research Inst. for Automation and Measurement, Poland
Tan, Ooi Kiang, Nanyang Technological University, Singapore,
Tang, Dianping, Southwest University, China
Tang, Jaw-Luen, National Chung Cheng University, Taiwan
Teker, Kasif, Frostburg State University, USA
Thumbavanam Pad, Kartik, Carnegie Mellon University, USA
Tian, Gui Yun, University of Newcastle, UK
Tsiantos, Vassilios, Technological Educational Institute of Kaval, Greece
Tsigara, Anna, National Hellenic Research Foundation, Greece
Twomey, Karen, University College Cork, Ireland
Valente, Antonio, University, Vila Real, - U.T.A.D., Portugal
Vaseashta, Ashok, Marshall University, USA
Vazquez, Carmen, Carlos III University in Madrid, Spain
Vieira, Manuela, Instituto Superior de Engenharia de Lisboa, Portugal
Vigna, Benedetto, STMicroelectronics, Italy
Vrba, Radimir, Brno University of Technology, Czech Republic
Wandelt, Barbara, Technical University of Lodz, Poland
Wang, Jiangping, Xi'an Shiyou University, China
Wang, Kedong, Beihang University, China
Wang, Liang, Advanced Micro Devices, USA
Wang, Mi, University of Leeds, UK
Wang, Shinn-Fwu, Ching Yun University, Taiwan
Wang, Wei-Chih, University of Washington, USA
Wang, Wensheng, University of Pennsylvania, USA
Watson, Steven, Center for NanoSpace Technologies Inc., USA
Weiping, Yan, Dalian University of Technology, China
Wells, Stephen, Southern Company Services, USA
Wolkenberg, Andrzej, Institute of Electron Technology, Poland
Woods, R. Clive, Louisiana State University, USA
Wu, DerHo, National Pingtung Univ. of Science and Technology, Taiwan
Wu, Zhaoyang, Hunan University, China
Xiu Tao, Ge, Chuzhou University, China
Xu, Lisheng, The Chinese University of Hong Kong, Hong Kong
Xu, Tao, University of California, Irvine, USA
Yang, Dongfang, National Research Council, Canada
Yang, Wuqiang, The University of Manchester, UK
Yang, Xiaoling, University of Georgia, Athens, GA, USA
Yaping Dan, Harvard University, USA
Ymeti, Aurel, University of Twente, Netherland
Yong Zhao, Northeastern University, China
Yu, Haihu, Wuhan University of Technology, China
Yuan, Yong, Massey University, New Zealand
Yufera Garcia, Alberto, Seville University, Spain
Zagnoni, Michele, University of Southampton, UK
Zamani, Cyrus, Universitat de Barcelona, Spain
Zeni, Luigi, Second University of Naples, Italy
Zhang, Minglong, Shanghai University, China
Zhang, Quintao, University of California at Berkeley, USA
Zhang, Weiping, Shanghai Jiao Tong University, China
Zhang, Wenming, Shanghai Jiao Tong University, China
Zhang, Xueji, World Precision Instruments, Inc., USA
Zhong, Haoxiang, Henan Normal University, China
Zhu, Qing, Fujifilm Dimatix, Inc., USA
Zorzano, Luis, Universidad de La Rioja, Spain
Zourob, Mohammed, University of Cambridge, UK

Contents

Volume 111
Issue 12
December 2009

www.sensorsportal.com

ISSN 1726-5479

Research Articles

Effect of Uncertainty in the Reliability of the COTS based Hardware System and its Sensitivity Analysis <i>Y. B. Acharya and Vivek Goswami</i>	1
cLite – A Capacitive Signal Conditioning IC <i>Krauss Gudrun</i>	10
Fabrication Challenges for Realization of Wet Etching Based Comb Type Capacitive Microaccelerometer Structure <i>Shankar Dutta, R. Pal, P. Kumar, O. P. Hooda, J. Singh, Shaveta, G. Saxena, P. Datta and R. Chatterjee</i>	18
Stray Capacitances of an Air-Cored Eddy Current Sensor <i>Yi Jia, Henning Heuer, Susanne Hillmann, Norbert Meyendorf</i>	25
Design and Simulation of MOEMS Thermal Sensor Based on a Bimetallic Mechanism <i>Shahriar Kouravand</i>	38
Directivity Analysis of Piezoelectric Micromachined Ultrasonic Transducer Array <i>Yunlong Geng, Limei Xu, Xuesheng Li, Leon Xu</i>	45
Design of RF MEMS Switch with High Stability Effect at the Low Actuation Voltage <i>Bandana Mishra, Rajiv Panigrahi, Z. C. Alex</i>	58
Study of the Stability of Copper Fixed Point in Sealed Cells for Calibration of Noble Metal Thermocouples <i>Yasser A. Abdel-Aziz and Faten M. Megahed</i>	65
Reconfigurable Antenna for Medical Applications <i>Elizabeth Rufus and Zachariah C. Alex</i>	71
Numerical Analysis of an Oscillating Micromixer <i>B. Dennai, R. Khelifaoui, B. Benyoucef, A. Slimani, A. Maazouzi and A. Missoum</i>	79
Investigation of Wireless Sensor Deployment Schemes for In-Situ Measurement of Water Ice near Lunar South Pole <i>Jayesh P. Pabari, Y. B. Acharya and U. B. Desai</i>	86
Single-mode D-type Surface Plasmon Resonance Optical Fiber Sensor: Review <i>Ming-Hung Chiu</i>	106
Multimode D-type Optical Fiber Sensor Based on ATR Effect in Temperature Detection <i>Ming-Hung Chiu, Po-Chin Chiu, Liu-Yi Hsien, Wei-Ching Chuang and Fuh-Shyang Juang</i>	125

A Comparative Assessment of Performance of Moisture Controllers for a Real Time Industrial Paper Machine Model <i>K. Ramkumar and A. Ramakalyan</i>	132
Photoresponse of LAPS with Different Species Membranes: Modeling and Simulation <i>Ferdinand Gasparyan</i>	141
Effect of Firing Temperature on Humidity Sensing Properties of SnO₂ Thick Film Resistor <i>R. Y. Borse and A. S. Garde</i>	155

Authors are encouraged to submit article in MS Word (doc) and Acrobat (pdf) formats by e-mail: editor@sensorsportal.com
Please visit journal's webpage with preparation instructions: <http://www.sensorsportal.com/HTML/DIGEST/Submission.htm>

International Frequency Sensor Association (IFSA).

SENSORDEVICES 2010:

The First International Conference
on Sensor Device Technologies and Applications

July 18 - 25, 2010 - Venice, Italy



The inaugural event SENSORDEVICES 2010, The First International Conference on Sensor Device Technologies and Applications, initiates a series of events focusing on sensor devices themselves, the technology-capturing style of sensors, special technologies, signal control and interfaces, and particularly sensors-oriented applications. The evolution of the nano- and microtechnologies, nanomaterials, and the new business services make the sensor device industry and research on sensor-themselves very challenging.

Conference tracks

Sensor devices
Sensor device technologies
Sensors signal conditioning and interfacing circuits

Medical devices and sensors applications
Sensors domain-oriented devices, technologies, and applications
Sensor-based localization and tracking technologies

Important dates

Submission (full paper): February 20, 2010
Notification: March 25, 2010
Registration: April 15, 2010
Camera ready: April 20, 2010



<http://www.iaria.org/conferences2010/SENSORDEVICES10.html>

Numerical Analysis of an Oscillating Micromixer

*B. Dennai, *R. Khelfaoui, **B. Benyoucef, *A. Slimani, *A. Maazouzi
and *A. Missoum

* Laboratory LPDS, University of Bechar, Algeria

Tel: 0021349819204, fax: 0021349819204

** University of Abu Bakr Belkaid, Tlemcen, Algeria

E-mail: khelfaouidz@yahoo.fr

Received: 21 October 2009 /Accepted: 22 December 2009 /Published: 30 December 2009

Abstract: Micromixing is particularly interesting for many microfluidic applications. In micrometric size devices, reaching an efficient mixing is often difficult, due to laminarization of the flow. Several solutions are proposed in the literature to overcome this issue. As an example, efficient mixing may be obtained using a secondary pulsed flow to destabilize the diffusion layer between the two fluids to mix. This layer is then stretched and folded, which leads to an improved chaotic mixing [Dodge et al., 2004]. However, this technique requires a specific actuation, which makes the microsystem more complex. In this paper, we study an autopulsating micromixer based on a microfluidic oscillator, the principle of which takes advantage of the Coanda effect. Oscillations of the flow are self generated, which widely simplifies the micromixer design. Different geometries are numerically investigated both for liquid and gaseous fluids using the CFD Code. The simulated frequency of oscillations is compared with analytical predictions and experimental data obtained in a millimetric sized mixer. Mixing efficiency is quantified and discussed in function of the flow structure, both for incompressible and compressible fluids, for millimetric and micrometric sizes *Copyright © 2009 IFSA.*

Keywords: Micro fluidic, Oscillator, Micro mixer

1. Introduction

Within the last decade the world of the "bio" micro technology has growth up, more to many university and private groups which have been developing micro systems for biomedical and chemical applications. A whole realized tasks on macroscopic scale realized in laboratory are miniaturized to mixing. Tow types of micro mixer are used in micro fluidic, active and passive.

The characteristic size of the channels is generally about a few tens of microns. This miniaturization involves series of fundamental problems related to the fluid mechanic. Indeed, at these scales, the fluidic flows are laminar [1]. The first efforts to reduce of the waiting time are focused on the reduction of the characteristic time of molecular diffusion, which varies according to the square of the characteristic length system. Thus, the subdivision of principal channel in several sub channels of lower size, which constitute the output channel was presented by Branebjerg (1996) [2].

The mixing of two fluids can be improved when the interface between the fluids increases while being stretching and while bending, so that the diffusion between the fluids occurs of variety from a certain small distance. The same micro mixer used by Volpert M. (2000) [3-4] is used to realize several effective mixing flows under various conditions. The working principle of this device consists in disturbing the flow of the two liquid jets moving along the principal channel by flow oscillations generated by three pairs of lateral canals. The device is called transverse micro mixer.

In these cases, the oscillators use special designed geometric configurations, identified by the absence of moving parts, to create an environment where self-induced, sustained oscillations will occur [6, 7, 8], they can be used as flow meters. A novel fluidic oscillator has been developed and tested by V. Tesar, make this oscillator attractive as mixer of reactants for micro reactor application [9].

There have been a lot of studies on micro mixers and passive ones, which have advantages on the simplicity of biological studies. The auto pulsed micro mixer was suggested for investigation and fabrication of micro-oscillator. In this work, from basic concept of the oscillator, we have designed a new type of passive micro mixer.

2. Design and Operation of the Oscillator Description

Micro oscillator was obtained from wall attachment micro fluidic amplifiers using a feedback loop from the outputs to the control input, Fig. 1 [10].

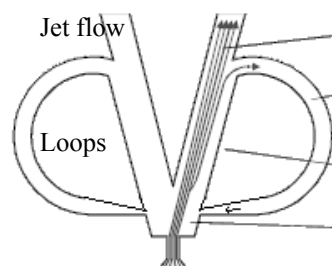

Fig. 1. Description oscillator.

The principle of oscillators is based on a fluid jet, which is injected into the oscillator and bends due to small fluctuations towards one of the attachment walls. The fluid flow on the bend side of the jet, is restricted and a low-pressure regime is created, this causes the jet to be attached to the wall (Coanda effect) [7]

3. Approximation of the Oscillation Frequency

The period of oscillations is determined by the switching time from the attachment wall to another and the transmission time through the feedback channel [7, 8]. The frequency is determined by the

following expression:

$$f = \frac{1}{2.(t_s + t_t)}, \quad (1)$$

For liquids flow, generally the frequency of oscillation is strongly dependent on the switching time [8], it is given as in following expression:

$$f = \frac{1}{2.(t_t)}, \quad (2)$$

For gases, the frequency of a bistable feedback oscillator by functions of the jet travel time, of the jet switching time, and the acoustic travel time [11]. In a rough approximation, it is given as in the following expression:

$$f = \frac{\sqrt{\gamma.r}}{2.(l_b + 2.L_o)} \sqrt{T}, \quad (3)$$

T temperature K, and $\gamma=1.4$ for air, r gas constant, l_b feedback loop length, L_o outlet length. The Fig. 2 represents three cases of frequency.

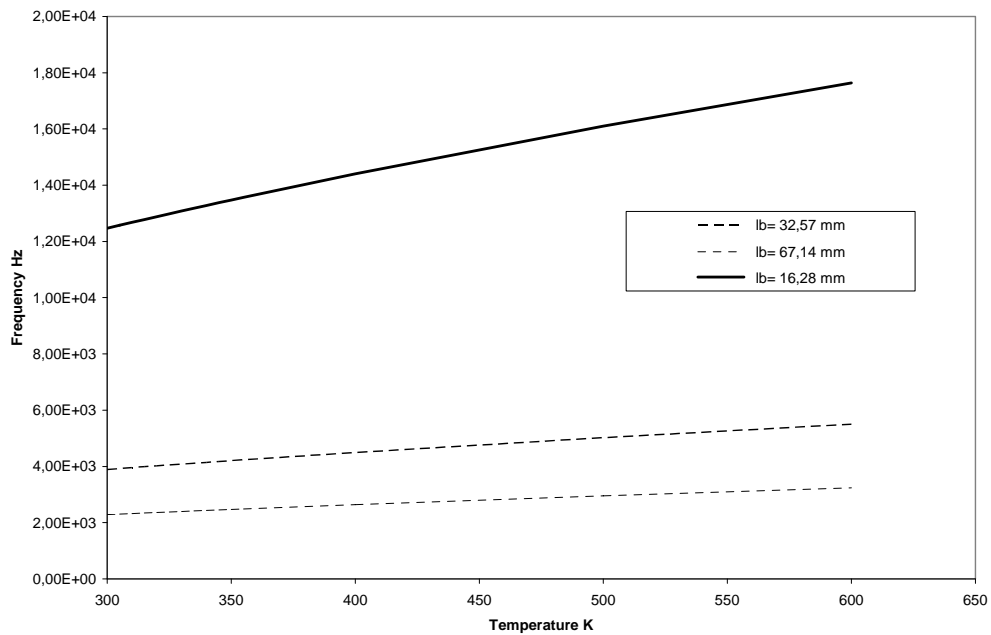

Fig. 2. Frequency upon temperature.

To investigate the performance of the fluidic oscillator volume finite simulations using the software CFD were carried out. With a given pressure difference between the input and the output ports, a transient calculation was performed to determine the velocity and pressure distribution in the fluidic oscillator.

Fig. 3 presents the geometrical characteristics of the microfluidic oscillators defined in this work. The length of the feedback channels is 3263 μm .

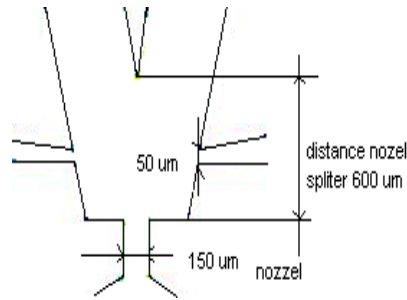

Fig. 3. Geometrical characteristics.

The following numerical results are obtained for air and turbulent regime of the Reynolds number at nozzle 26600, for millimetric sizes.

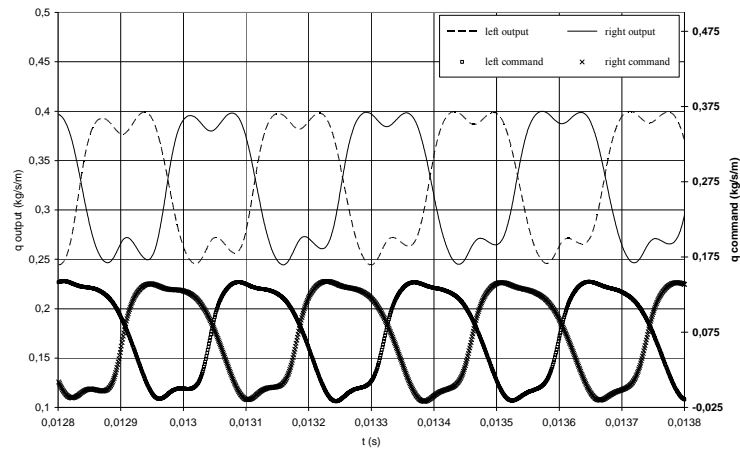

Fig. 4. Mass flow distribution, millimetric size.

The results of micrometric size cases are obtained for air and laminar regime of the Reynolds number at nozzle 2660.

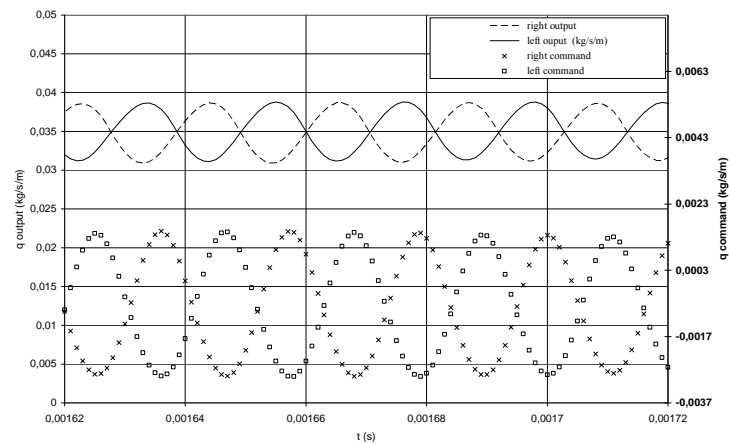

Fig. 5. Mass flow distribution, micrometric size.

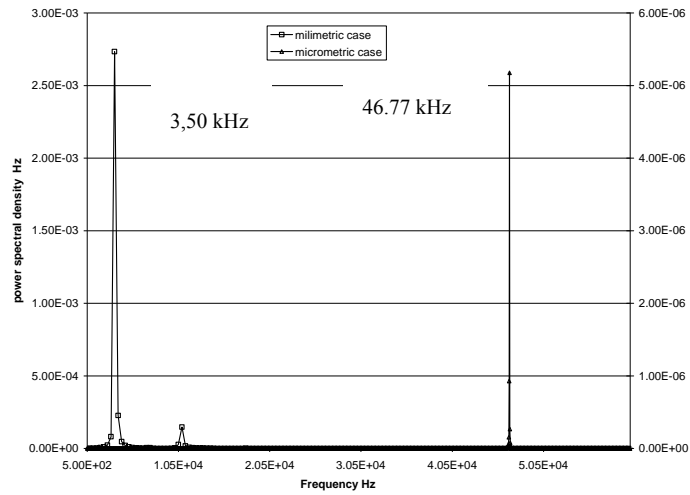

Fig. 6. Spectral power density of milimetric and micrometric size, and air flow.

Next results are presented for liquids flow for the Reynolds number equal to 18998 and millimetric size, and time step equal to 10^{-5} s.

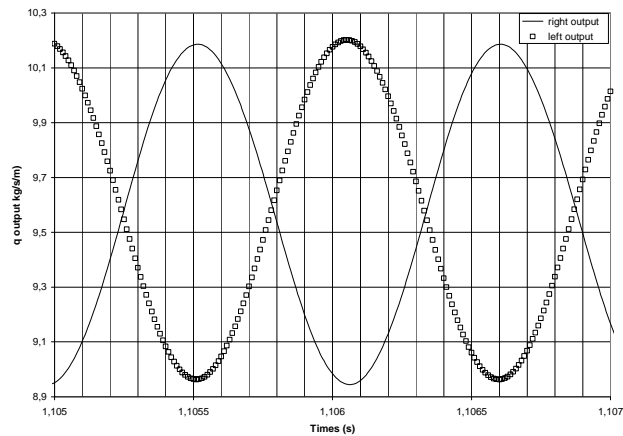

Fig. 7. Mass flow distribution, liquid flow.

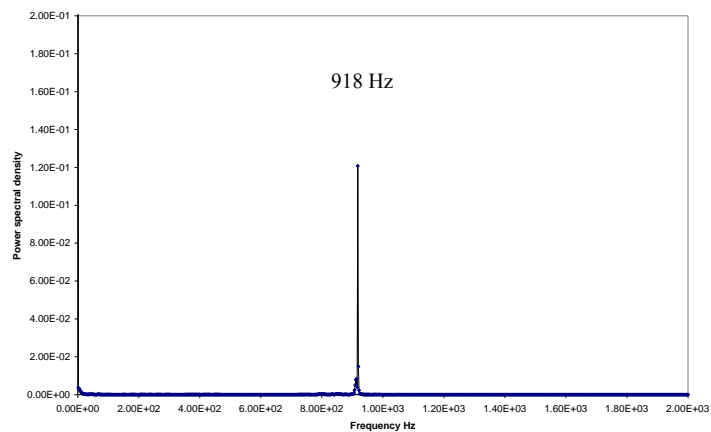

Fig. 8. Spectral power density for liquid flow.

4. Oscillating Micromixer Design

The structure of the oscillating micromixer proposed in this work consists of two connected oscillators, as shown schematically in Fig. 9.

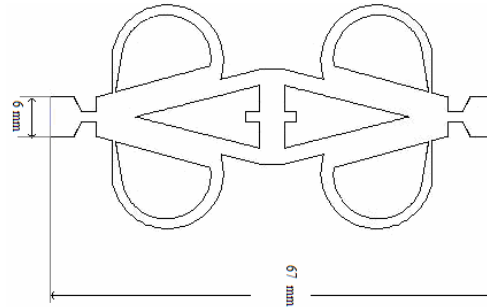

Fig. 9. Oscillating micromixer design.

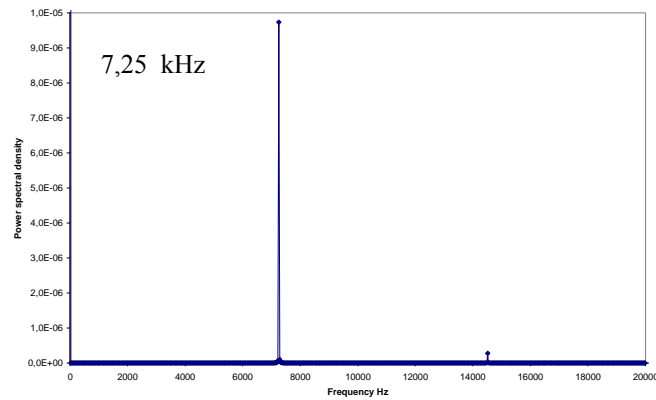

Fig. 10. Spectral power density of oscillating micromixer.

5. Mixture Estimation

For two outputs oscillating mixer, the distribution of mass fraction was presented

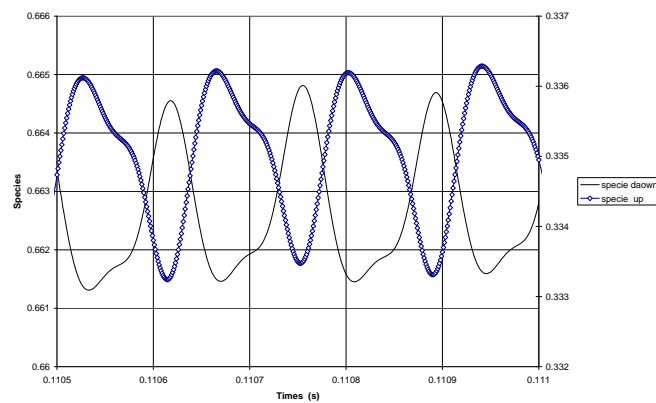

Fig. 11. Mass fraction distribution outlet.

5. Conclusions

The performance of oscillating micromixer with millimetric and micrometric size was simulated by using CFD Code. The first results of these numerical calculations indicate the evaluation of the fluidic oscillator oscillating frequency; the second one consists of oscillating micromixer frequency and mass fraction with millimetric size. The experimental investigation reports the oscillation was detected from 0.25 bars. In perspective we propose to undertake an experimental study to estimate a mass fraction mixture.

References

- [1]. P. Tabeling, Introduction à la micro fluidique, *Collection Echelles*, Berlin, 2003.
 - [2]. Volker Hessel, Holger Löwe, Friedhelm Schönfeld, Micromixer-a review on passive and active mixing principles, *Chemical Engineering Science*, 60, 2005, pp. 2479-2501.
 - [3]. Gauthier, Y., La logique interne des théories physiques, *Coll. Analytiques, Bellarmin-Vrin*, Montréal-Paris, 1992.
 - [4]. Arash Dodge, Marie-Caroline Julien, Yi-Kuen Lee, X. Niu, Fridolin Okkels, Patrick Tabeling, An example of a chaotic micromixer: the cross-channel micromixer, *C. R. Physique*, 5, 2004, pp. 557-563
 - [5]. M. Koch, H. Witt, A. G. R. Evans and A. Brunnschweiler, Improved characterization technique for micromixers, *J. Micromech. Microeng.*, 9, 1999, pp. 156–158.
 - [6]. A. Bertsch, S. Heimgartner, P. Cousseau and P. Tenaud, Static micromixers based on large scale industrial mixer geometry, *LAB on a chip*, 2001, 1, pp. 56-60.
 - [7]. U. Gebhard, H. Hein and U. Schmidt, Numerical investigation of fluidic micro-oscillators, *J. Micromech, Microeng.*, 6., 1996, pp.115-117.
 - [8]. Eliphas Wagner Simões, Rogerio Furlan, Roerto Eduardo Bruzetti Leminski, Numerical Oscillator For gas flow control and measurement, *J Flow Measurement and Instrumentation*, 16, 2005, pp.7-12.
 - [9]. V. Tesar, J. R. Tippetts, Y. Y. Low, Oscillator mixer for chemical microreactors, *9th international symposium on flow visualisation*, 2000, 298, pp. 1-298. 7.
 - [10]. K. Foster, C. A. Parker, Fluidic Components & Circuits, 1970, *John Wiley & Soon Ltd*, pp. 265-273.
 - [11]. W. Gerhard, Fluidic temperature sensor investigation for high gas temperatures, *AGARDograph*, 1969, p. 135.
-

Guide for Contributors

Aims and Scope

Sensors & Transducers Journal (ISSN 1726-5479) provides an advanced forum for the science and technology of physical, chemical sensors and biosensors. It publishes state-of-the-art reviews, regular research and application specific papers, short notes, letters to Editor and sensors related books reviews as well as academic, practical and commercial information of interest to its readership. Because it is an open access, peer review international journal, papers rapidly published in *Sensors & Transducers Journal* will receive a very high publicity. The journal is published monthly as twelve issues per annual by International Frequency Association (IFSA). In addition, some special sponsored and conference issues published annually. *Sensors & Transducers Journal* is indexed and abstracted very quickly by Chemical Abstracts, IndexCopernicus Journals Master List, Open J-Gate, Google Scholar, etc.

Topics Covered

Contributions are invited on all aspects of research, development and application of the science and technology of sensors, transducers and sensor instrumentations. Topics include, but are not restricted to:

- Physical, chemical and biosensors;
- Digital, frequency, period, duty-cycle, time interval, PWM, pulse number output sensors and transducers;
- Theory, principles, effects, design, standardization and modeling;
- Smart sensors and systems;
- Sensor instrumentation;
- Virtual instruments;
- Sensors interfaces, buses and networks;
- Signal processing;
- Frequency (period, duty-cycle)-to-digital converters, ADC;
- Technologies and materials;
- Nanosensors;
- Microsystems;
- Applications.

Submission of papers

Articles should be written in English. Authors are invited to submit by e-mail editor@sensorsportal.com 8-14 pages article (including abstract, illustrations (color or grayscale), photos and references) in both: MS Word (doc) and Acrobat (pdf) formats. Detailed preparation instructions, paper example and template of manuscript are available from the journal's webpage: <http://www.sensorsportal.com/HTML/DIGEST/Submission.htm> Authors must follow the instructions strictly when submitting their manuscripts.

Advertising Information

Advertising orders and enquires may be sent to sales@sensorsportal.com Please download also our media kit: http://www.sensorsportal.com/DOWNLOADS/Media_Kit_2009.pdf

 **WILEY**
1807-2007

KNOWLEDGE FOR GENERATIONS

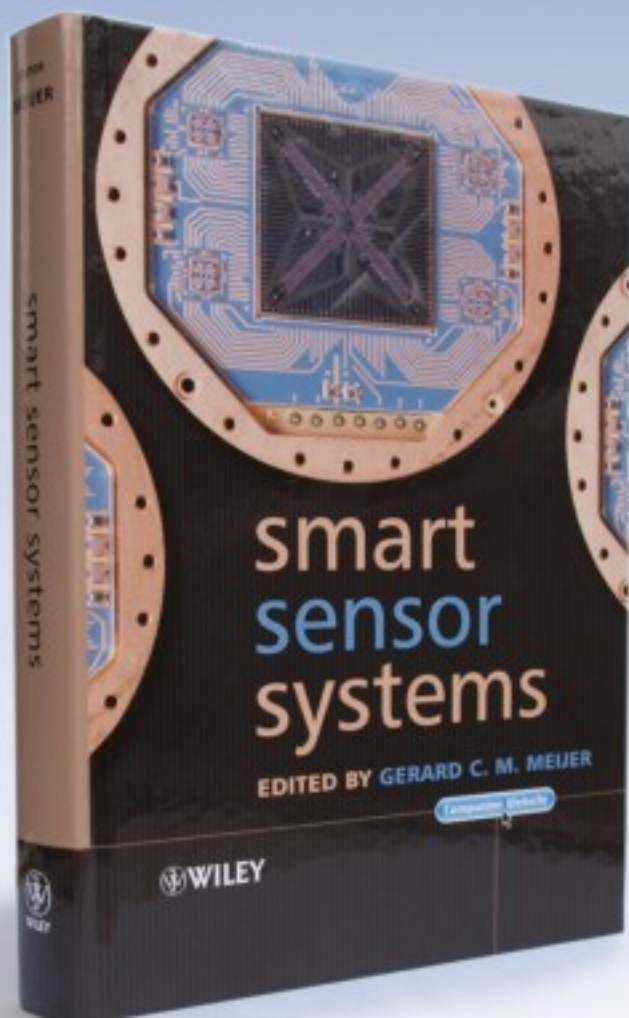

'Written by an internationally-recognized team of experts, this book reviews recent developments in the field of smart sensors systems, providing complete coverage of all important systems aspects. It takes a multidisciplinary approach to the understanding, design and use of smart sensor systems, their building blocks and methods of signal processing.'



Order online:

http://www.sensorsportal.com/HTML/BOOKSTORE/Smart_Sensor_Systems.htm

www.sensorsportal.com