

ISSN 1726-5479

SENSORS & TRANSDUCERS

vol. 112
1
/10

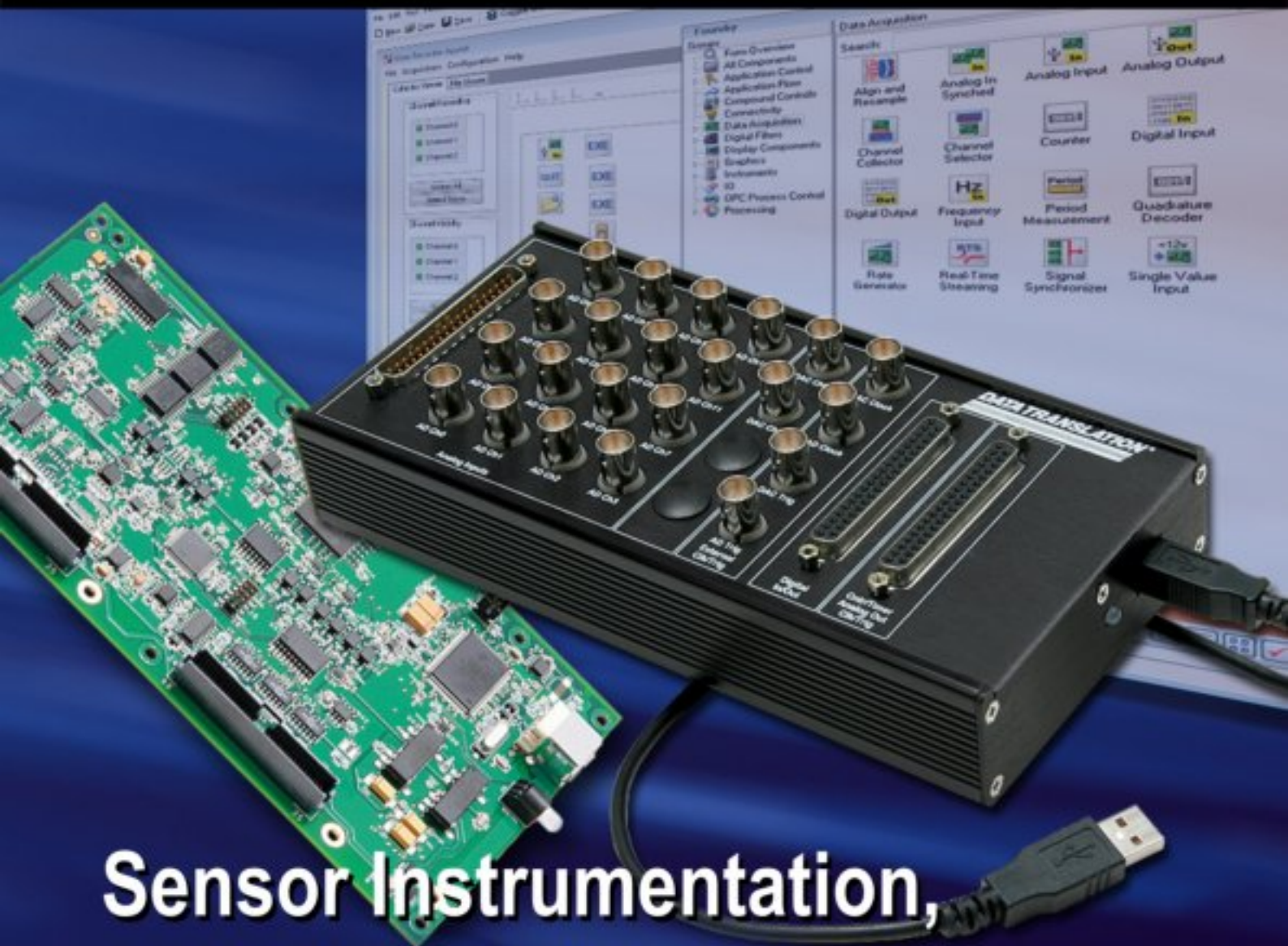

Sensor Instrumentation, DAQ and Virtual Instruments

International Frequency Sensor Association Publishing



Editors-in-Chief: professor Sergey Y. Yurish,
Phone: +34 696067716, fax: +34 93 4011989, e-mail: editor@sensorsportal.com

Editors for Western Europe

Meijer, Gerard C.M., Delft University of Technology, The Netherlands
Ferrari, Vittorio, Università di Brescia, Italy

Editor South America

Costa-Felix, Rodrigo, Inmetro, Brazil

Editor for Eastern Europe

Sachenko, Anatoly, Ternopil State Economic University, Ukraine

Editors for North America

Datskos, Panos G., Oak Ridge National Laboratory, USA
Fabien, J. Josse, Marquette University, USA
Katz, Evgeny, Clarkson University, USA

Editor for Asia

Ohyama, Shinji, Tokyo Institute of Technology, Japan

Editor for Asia-Pacific

Mukhopadhyay, Subhas, Massey University, New Zealand

Editorial Advisory Board

- Abdul Rahim, Ruzairi**, Universiti Teknologi, Malaysia
Ahmad, Mohd Noor, Northern University of Engineering, Malaysia
Annamalai, Karthigeyan, National Institute of Advanced Industrial Science and Technology, Japan
Arcega, Francisco, University of Zaragoza, Spain
Arguel, Philippe, CNRS, France
Ahn, Jae-Pyoung, Korea Institute of Science and Technology, Korea
Arndt, Michael, Robert Bosch GmbH, Germany
Ascoli, Giorgio, George Mason University, USA
Atalay, Selcuk, Inonu University, Turkey
Atghiaee, Ahmad, University of Tehran, Iran
Augutis, Vygantas, Kaunas University of Technology, Lithuania
Avachit, Patil Lalchand, North Maharashtra University, India
Ayesh, Aladdin, De Montfort University, UK
Bahreyni, Behraad, University of Manitoba, Canada
Baliga, Shankar, B., General Monitors Transnational, USA
Baoxian, Ye, Zhengzhou University, China
Barford, Lee, Agilent Laboratories, USA
Barlingay, Ravindra, RF Arrays Systems, India
Basu, Sukumar, Jadavpur University, India
Beck, Stephen, University of Sheffield, UK
Ben Bouzid, Sihem, Institut National de Recherche Scientifique, Tunisia
Benachaiba, Chellali, Universitaire de Bechar, Algeria
Binnie, T. David, Napier University, UK
Bischoff, Gerlinde, Inst. Analytical Chemistry, Germany
Bodas, Dhananjay, IMTEK, Germany
Borges Carval, Nuno, Universidade de Aveiro, Portugal
Bousbia-Salah, Mounir, University of Annaba, Algeria
Bouvet, Marcel, CNRS – UPMC, France
Brudzewski, Kazimierz, Warsaw University of Technology, Poland
Cai, Chenxin, Nanjing Normal University, China
Cai, Qingyun, Hunan University, China
Campanella, Luigi, University La Sapienza, Italy
Carvalho, Vitor, Minho University, Portugal
Cecelja, Franjo, Brunel University, London, UK
Cerda Belmonte, Judith, Imperial College London, UK
Chakrabarty, Chandan Kumar, Universiti Tenaga Nasional, Malaysia
Chakravorty, Dipankar, Association for the Cultivation of Science, India
Changhai, Ru, Harbin Engineering University, China
Chaudhari, Gajanan, Shri Shivaji Science College, India
Chavali, Murthy, VIT University, Tamil Nadu, India
Chen, Jiming, Zhejiang University, China
Chen, Rongshun, National Tsing Hua University, Taiwan
Cheng, Kuo-Sheng, National Cheng Kung University, Taiwan
Chiang, Jeffrey (Cheng-Ta), Industrial Technol. Research Institute, Taiwan
Chiriac, Horia, National Institute of Research and Development, Romania
Chowdhuri, Arijit, University of Delhi, India
Chung, Wen-Yaw, Chung Yuan Christian University, Taiwan
Corres, Jesus, Universidad Publica de Navarra, Spain
Cortes, Camilo A., Universidad Nacional de Colombia, Colombia
Courtois, Christian, Universite de Valenciennes, France
Cusano, Andrea, University of Sannio, Italy
D'Amico, Arnaldo, Università di Tor Vergata, Italy
De Stefano, Luca, Institute for Microelectronics and Microsystem, Italy
Deshmukh, Kiran, Shri Shivaji Mahavidyalaya, Barshi, India
Dickert, Franz L., Vienna University, Austria
Dieguez, Angel, University of Barcelona, Spain
Dimitropoulos, Panos, University of Thessaly, Greece
Ding, Jianning, Jiangsu Polytechnic University, China
Djordjevic, Alexandar, City University of Hong Kong, Hong Kong
Donato, Nicola, University of Messina, Italy
Donato, Patricio, Universidad de Mar del Plata, Argentina
Dong, Feng, Tianjin University, China
Drljaca, Predrag, Instersema Sensoric SA, Switzerland
Dubey, Venketesh, Bournemouth University, UK
Enderle, Stefan, Univ. of Ulm and KTB Mechatronics GmbH, Germany
Erdem, Gursan K. Arzum, Ege University, Turkey
Erkmen, Aydan M., Middle East Technical University, Turkey
Estelle, Patrice, Insa Rennes, France
Estrada, Horacio, University of North Carolina, USA
Faiz, Adil, INSA Lyon, France
Fericean, Sorin, Balluff GmbH, Germany
Fernandes, Joana M., University of Porto, Portugal
Francioso, Luca, CNR-IMM Institute for Microelectronics and Microsystems, Italy
Francis, Laurent, University Catholique de Louvain, Belgium
Fu, Weiling, South-Western Hospital, Chongqing, China
Gaura, Elena, Coventry University, UK
Geng, Yanfeng, China University of Petroleum, China
Gole, James, Georgia Institute of Technology, USA
Gong, Hao, National University of Singapore, Singapore
Gonzalez de la Rosa, Juan Jose, University of Cadiz, Spain
Granel, Annette, Goteborg University, Sweden
Graff, Mason, The University of Texas at Arlington, USA
Guan, Shan, Eastman Kodak, USA
Guillet, Bruno, University of Caen, France
Guo, Zhen, New Jersey Institute of Technology, USA
Gupta, Narendra Kumar, Napier University, UK
Hadjiloucas, Sillas, The University of Reading, UK
Haider, Mohammad R., Sonoma State University, USA
Hashsham, Syed, Michigan State University, USA
Hasni, Abdelhafid, Bechar University, Algeria
Hernandez, Alvaro, University of Alcalá, Spain
Hernandez, Wilmar, Universidad Politecnica de Madrid, Spain
Homentcovschi, Dorel, SUNY Binghamton, USA
Horstman, Tom, U.S. Automation Group, LLC, USA
Hsiai, Tzung (John), University of Southern California, USA
Huang, Jeng-Sheng, Chung Yuan Christian University, Taiwan
Huang, Star, National Tsing Hua University, Taiwan
Huang, Wei, PSG Design Center, USA
Hui, David, University of New Orleans, USA
Jaffrezic-Renault, Nicole, Ecole Centrale de Lyon, France
Jaime Calvo-Galleg, Jaime, Universidad de Salamanca, Spain
James, Daniel, Griffith University, Australia
Janting, Jakob, DELTA Danish Electronics, Denmark
Jiang, Liudi, University of Southampton, UK
Jiang, Wei, University of Virginia, USA
Jiao, Zheng, Shanghai University, China
John, Joachim, IMEC, Belgium
Kalach, Andrew, Voronezh Institute of Ministry of Interior, Russia
Kang, Moonho, Sunmoon University, Korea South
Kaniusas, Eugenijus, Vienna University of Technology, Austria
Katake, Anup, Texas A&M University, USA
Kausel, Wilfried, University of Music, Vienna, Austria
Kavasoglu, Nese, Mugla University, Turkey
Ke, Cathy, Tyndall National Institute, Ireland
Khan, Asif, Aligarh Muslim University, Aligarh, India
Sapozhnikova, Ksenia, D.I.Mendeleyev Institute for Metrology, Russia

Kim, Min Young, Kyungpook National University, Korea South
Ko, Sang Choon, Electronics. and Telecom. Research Inst., Korea South
Kockar, Hakan, Balikesir University, Turkey
Kotulska, Malgorzata, Wroclaw University of Technology, Poland
Kratz, Henrik, Uppsala University, Sweden
Kumar, Arun, University of South Florida, USA
Kumar, Subodh, National Physical Laboratory, India
Kung, Chih-Hsien, Chang-Jung Christian University, Taiwan
Lacnjevac, Caslav, University of Belgrade, Serbia
Lay-Ekuakille, Aime, University of Lecce, Italy
Lee, Jang Myung, Pusan National University, Korea South
Lee, Jun Su, Amkor Technology, Inc. South Korea
Lei, Hua, National Starch and Chemical Company, USA
Li, Genxi, Nanjing University, China
Li, Hui, Shanghai Jiaotong University, China
Li, Xian-Fang, Central South University, China
Liang, Yuanchang, University of Washington, USA
Liawruangrath, Saisune, Chiang Mai University, Thailand
Liew, Kim Meow, City University of Hong Kong, Hong Kong
Lin, Hermann, National Kaohsiung University, Taiwan
Lin, Paul, Cleveland State University, USA
Linderholm, Pontus, EPFL - Microsystems Laboratory, Switzerland
Liu, Aihua, University of Oklahoma, USA
Liu Changgeng, Louisiana State University, USA
Liu, Cheng-Hsien, National Tsing Hua University, Taiwan
Liu, Songqin, Southeast University, China
Lodeiro, Carlos, University of Vigo, Spain
Lorenzo, Maria Encarnacio, Universidad Autonoma de Madrid, Spain
Lukaszewicz, Jerzy Pawel, Nicholas Copernicus University, Poland
Ma, Zhanfang, Northeast Normal University, China
Majstorovic, Vidosav, University of Belgrade, Serbia
Marquez, Alfredo, Centro de Investigacion en Materiales Avanzados, Mexico
Matay, Ladislav, Slovak Academy of Sciences, Slovakia
Mathur, Prafull, National Physical Laboratory, India
Maurya, D.K., Institute of Materials Research and Engineering, Singapore
Mekid, Samir, University of Manchester, UK
Melnyk, Ivan, Photon Control Inc., Canada
Mendes, Paulo, University of Minho, Portugal
Mennell, Julie, Northumbria University, UK
Mi, Bin, Boston Scientific Corporation, USA
Minas, Graca, University of Minho, Portugal
Moghavvemi, Mahmoud, University of Malaya, Malaysia
Mohammadi, Mohammad-Reza, University of Cambridge, UK
Molina Flores, Esteban, Benemérita Universidad Autónoma de Puebla, Mexico
Moradi, Majid, University of Kerman, Iran
Morello, Rosario, University "Mediterranea" of Reggio Calabria, Italy
Mounir, Ben Ali, University of Sousse, Tunisia
Mulla, Imtiaz Sirajuddin, National Chemical Laboratory, Pune, India
Neelamegam, Periasamy, Sastra Deemed University, India
Neshkova, Milka, Bulgarian Academy of Sciences, Bulgaria
Oberhammer, Joachim, Royal Institute of Technology, Sweden
Ould Lahoucine, Cherif, University of Guelma, Algeria
Pamidighanta, Sayanu, Bharat Electronics Limited (BEL), India
Pan, Jisheng, Institute of Materials Research & Engineering, Singapore
Park, Joon-Shik, Korea Electronics Technology Institute, Korea South
Penza, Michele, ENEA C.R., Italy
Pereira, Jose Miguel, Instituto Politecnico de Setebal, Portugal
Petsev, Dimiter, University of New Mexico, USA
Pogacnik, Lea, University of Ljubljana, Slovenia
Post, Michael, National Research Council, Canada
Prance, Robert, University of Sussex, UK
Prasad, Ambika, Gulbarga University, India
Prateepasen, Asa, Kingmoungut's University of Technology, Thailand
Pullini, Daniele, Centro Ricerche FIAT, Italy
Pumera, Martin, National Institute for Materials Science, Japan
Radhakrishnan, S. National Chemical Laboratory, Pune, India
Rajanna, K., Indian Institute of Science, India
Ramadan, Qasem, Institute of Microelectronics, Singapore
Rao, Basuthkar, Tata Inst. of Fundamental Research, India
Raouf, Kosai, Joseph Fourier University of Grenoble, France
Reig, Candid, University of Valencia, Spain
Restivo, Maria Teresa, University of Porto, Portugal
Robert, Michel, University Henri Poincare, France
Rezazadeh, Ghader, Urmia University, Iran
Royo, Santiago, Universitat Politècnica de Catalunya, Spain
Rodriguez, Angel, Universidad Politécnica de Catalunya, Spain
Rothberg, Steve, Loughborough University, UK
Sadana, Ajit, University of Mississippi, USA
Sadeghian Marnani, Hamed, TU Delft, The Netherlands
Sandacci, Serghei, Sensor Technology Ltd., UK
Saxena, Vibha, Bhabha Atomic Research Centre, Mumbai, India
Schneider, John K., Ultra-Scan Corporation, USA
Seif, Selemani, Alabama A & M University, USA
Seifter, Achim, Los Alamos National Laboratory, USA
Sengupta, Deepak, Advance Bio-Photonics, India
Shearwood, Christopher, Nanyang Technological University, Singapore
Shin, Kyuho, Samsung Advanced Institute of Technology, Korea
Shmaliy, Yuriy, Kharkiv National Univ. of Radio Electronics, Ukraine
Silva Girao, Pedro, Technical University of Lisbon, Portugal
Singh, V. R., National Physical Laboratory, India
Slomovitz, Daniel, UTE, Uruguay
Smith, Martin, Open University, UK
Soleymanpour, Ahmad, Damghan Basic Science University, Iran
Somani, Prakash R., Centre for Materials for Electronics Technol., India
Srinivas, Talabattula, Indian Institute of Science, Bangalore, India
Srivastava, Arvind K., Northwestern University, USA
Stefan-van Staden, Raluca-Ioana, University of Pretoria, South Africa
Sumriddetchka, Sarun, National Electronics and Computer Technology Center, Thailand
Sun, Chengliang, Polytechnic University, Hong-Kong
Sun, Dongming, Jilin University, China
Sun, Junhua, Beijing University of Aeronautics and Astronautics, China
Sun, Zhiqiang, Central South University, China
Suri, C. Raman, Institute of Microbial Technology, India
Sysoev, Victor, Saratov State Technical University, Russia
Szewczyk, Roman, Industrial Research Inst. for Automation and Measurement, Poland
Tan, Ooi Kiang, Nanyang Technological University, Singapore
Tang, Dianping, Southwest University, China
Tang, Jaw-Luen, National Chung Cheng University, Taiwan
Teker, Kasif, Frostburg State University, USA
Thumbavanam Pad, Kartik, Carnegie Mellon University, USA
Tian, Gui Yun, University of Newcastle, UK
Tsiantos, Vassilios, Technological Educational Institute of Kaval, Greece
Tsigara, Anna, National Hellenic Research Foundation, Greece
Twomey, Karen, University College Cork, Ireland
Valente, Antonio, University, Vila Real, - U.T.A.D., Portugal
Vaseashta, Ashok, Marshall University, USA
Vazquez, Carmen, Carlos III University in Madrid, Spain
Vieira, Manuela, Instituto Superior de Engenharia de Lisboa, Portugal
Vigna, Benedetto, STMicroelectronics, Italy
Vrba, Radimir, Brno University of Technology, Czech Republic
Wandelt, Barbara, Technical University of Lodz, Poland
Wang, Jiangping, Xi'an Shiyou University, China
Wang, Kedong, Beihang University, China
Wang, Liang, Advanced Micro Devices, USA
Wang, Mi, University of Leeds, UK
Wang, Shinn-Fwu, Ching Yun University, Taiwan
Wang, Wei-Chih, University of Washington, USA
Wang, Wensheng, University of Pennsylvania, USA
Watson, Steven, Center for NanoSpace Technologies Inc., USA
Weiping, Yan, Dalian University of Technology, China
Wells, Stephen, Southern Company Services, USA
Wolkenberg, Andrzej, Institute of Electron Technology, Poland
Woods, R. Clive, Louisiana State University, USA
Wu, DerHo, National Pingtung Univ. of Science and Technology, Taiwan
Wu, Zhaoyang, Hunan University, China
Xiu Tao, Ge, Chuzhou University, China
Xu, Lisheng, The Chinese University of Hong Kong, Hong Kong
Xu, Tao, University of California, Irvine, USA
Yang, Dongfang, National Research Council, Canada
Yang, Wuqiang, The University of Manchester, UK
Yang, Xiaoling, University of Georgia, Athens, GA, USA
Yaping Dan, Harvard University, USA
Ymeti, Aurel, University of Twente, Netherland
Yong Zhao, Northeastern University, China
Yu, Haihu, Wuhan University of Technology, China
Yuan, Yong, Massey University, New Zealand
Yufera Garcia, Alberto, Seville University, Spain
Zakaria, Zulkarnay, University Malaysia Perlis, Malaysia
Zagnoni, Michele, University of Southampton, UK
Zamani, Cyrus, Universitat de Barcelona, Spain
Zeni, Luigi, Second University of Naples, Italy
Zhang, Minglong, Shanghai University, China
Zhang, Quintao, University of California at Berkeley, USA
Zhang, Weiping, Shanghai Jiao Tong University, China
Zhang, Wenming, Shanghai Jiao Tong University, China
Zhang, Xueji, World Precision Instruments, Inc., USA
Zhong, Haoxiang, Henan Normal University, China
Zhu, Qing, Fujifilm Dimatix, Inc., USA
Zorzano, Luis, Universidad de La Rioja, Spain
Zourob, Mohammed, University of Cambridge, UK

Contents

Volume 112
Issue 1
January 2010

www.sensorsportal.com

ISSN 1726-5479

Research Articles

Design of an Acoustic Displacement Transducer <i>Tariq Al Mograbi, Mohammad A. K. Alia, Mohammad Abuzalata</i>	1
Vibration Analysis Based on Hammer Impact for Fouling Detection using Microphone and Accelerometer as Sensors <i>Jaidilson Silva, Antonio Marcus Lima, Helmut Neff and José Sérgio Rocha Neto</i>	10
Simulation of the Two-Phase Liquid – Gas Flow through Ultrasonic Transceivers Application in Ultrasonic Tomography <i>Zulkarnay Zakaria, Mohd Hafiz Fazalul Rahiman, Ruzairi Abdul Rahim</i>	24
Image Reconstructions of a Portable Optical CT-Scan Using an NIR Light Source <i>Margi Sasono and Hariyadi Soetedjo</i>	39
Statistical Feature Extraction and Recognition of Beverages Using Electronic Tongue <i>P. C. Panchariya and A. H. Kiranmayee</i>	47
Modeling and Verification of Heat Fields by Virtual Instrumentation <i>Libor Hargaš, Dušan Koniar, Miroslav Hrianka, Anna Příkopová</i>	64
PC Based Instrument for the Measurement of Dielectric Constant of Liquids <i>V. V. Ramana C. H. and Malakondaiah K.</i>	73
Development of Laser LEDs Based a Programmable Optical Sensor for Detection of Environmental Pollutants <i>Amit K. Sharma and R. K. Tiwari</i>	80
Performance Evaluation and Robustness Testing of Advanced Oscilloscope Triggering Schemes <i>Shakeb A. Khan, Alka Nigam, A. K. Agarwala, Mini S. Thomas</i>	95
Design and Development of an Embedded System for Testing the Potentiometer Linearity <i>Raghavendra Rao Kanchi, Nagamani Gosala</i>	107
Development of an FPGA Based Embedded System for High Speed Object Tracking <i>Chandrashekar Matham, Nagabhushan Raju Konduru</i>	118
A New Algorithm of Compensation of the Time Interval Error GPS-Based Measurements <i>Jonny Paul Zavala de Paz, Yuriy S. Shmaliy</i>	124
Colour Determination and Change of Sensory Properties of Mayonnaise with Different Contents of Oil depending on Length of Storage <i>Višnja M. Sikimić, Jovanka V. Popov-Raljić, Branislav P. Zlatković, Nada Lakić</i>	138
Dynamically Functioning Structure and Problem of Measurements of Rapidly Time-Varying Processes: Dream or Reality <i>George Abramchuk, Kristina Abramchuk</i>	166

SENSORDEVICES 2010:

The First International Conference
on Sensor Device Technologies and Applications

July 18 - 25, 2010 - Venice, Italy



The inaugural event SENSORDEVICES 2010, The First International Conference on Sensor Device Technologies and Applications, initiates a series of events focusing on sensor devices themselves, the technology-capturing style of sensors, special technologies, signal control and interfaces, and particularly sensors-oriented applications. The evolution of the nano- and microtechnologies, nanomaterials, and the new business services make the sensor device industry and research on sensor-themselves very challenging.

Conference tracks

Sensor devices
Sensor device technologies
Sensors signal conditioning and interfacing circuits

Medical devices and sensors applications
Sensors domain-oriented devices, technologies, and applications
Sensor-based localization and tracking technologies

Important dates

Submission (full paper): February 20, 2010
Notification: March 25, 2010
Registration: April 15, 2010
Camera ready: April 20, 2010



<http://www.iaria.org/conferences2010/SENSORDEVICES10.html>

SENSORCOMM 2010:

The Fourth International Conference
on Sensor Technologies and Applications

July 18 - 25, 2010 - Venice, Italy



SENSORCOMM 2010 (The Fourth International Conference on Sensor Technologies and Applications) is a multi-track event covering related topics on theory and practice on wired and wireless sensors and sensor networks. The topics suggested can be discussed in term of concepts, state of the art, research, standards, implementations, running experiments, applications, and industrial case studies.

Conference tracks

APASN Architectures, protocols and algorithms of sensor networks
MECSN Energy, management and control of sensor networks
RASQOFT Resource allocation, services, QoS and fault tolerance in sensor networks
PESMOSN Performance, simulation and modelling of sensor networks
SEMOSN Security and monitoring of sensor networks
SECSN Sensor circuits and sensor devices
RIWISN Radio issues in wireless sensor networks
SAPSN Software, applications and programming of sensor networks
DAIPSN Data allocation and information in sensor networks
DISN Deployments and implementations of sensor networks
UNWAT Under water sensors and systems
ENOPT Energy optimization in wireless sensor networks

Important dates

Submission (full paper): February 20, 2010
Notification: March 25, 2010
Registration: April 15, 2010
Camera ready: April 20, 2010

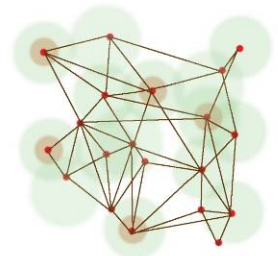

<http://www.iaria.org/conferences2010/SENSORCOMM10.html>

Authors are encouraged to submit article in MS Word (doc) and Acrobat (pdf) formats by e-mail: editor@sensorsportal.com
Please visit journal's webpage with preparation instructions: <http://www.sensorsportal.com/HTML/DIGEST/Submission.htm>

Modeling and Verification of Heat Fields by Virtual Instrumentation

Libor HARGAŠ, Dušan KONIAR, Miroslav HRIANKA, Anna PRÍKOPOVÁ

Department of Mechatronics and Electronics, Faculty of Electrical Engineering,

University of Žilina, Univerzitná 1, 010 26, Žilina, Slovak republic

E-mail: Libor.Hargas@fel.uniza.sk

Received: 18 December 2009 /Accepted: 22 January 2010 /Published: 29 January 2010

Abstract: This paper introduces about simulation and verification of heat relations in DC/DC converter as a part of various mechatronics systems. Heat transfer is the transition of thermal energy from a heated item to a cooler item. Results of simulation were compared with values obtained by measurement with virtual instruments. Measurements were made at various operating conditions of DC/DC converter. This measurement gives idea about the heat transfer at time dependences. *Copyright © 2010 IFSA.*

Keywords: Thermal analysis, Heat transfer, LabVIEW

1. DC/DC Converters

DC to DC converters are important in portable electronic devices such as cellular phones, laptop computers or engines, which are supplied with power from batteries primarily. Such mechatronics devices often contain several sub-electrical circuits, each with its own voltage level requirement different than that supplied by the battery or an external supply (sometimes higher or lower than the supply voltage, and possibly even negative voltage - Fig. 1). Additionally, the battery voltage declines as its stored power is drained. Switched DC to DC converters offer a method to increase voltage from a partially lowered battery voltage thereby saving space instead of using multiple batteries to accomplish the same thing [1].

The main function of DC/DC converter is conversion of input direct voltage to another direct voltage. DC/DC converter can work in some modes: boost or step-up converter, buck or step-down converter and inverting mode. The principle scheme of measured boost converter is at Fig. 2.

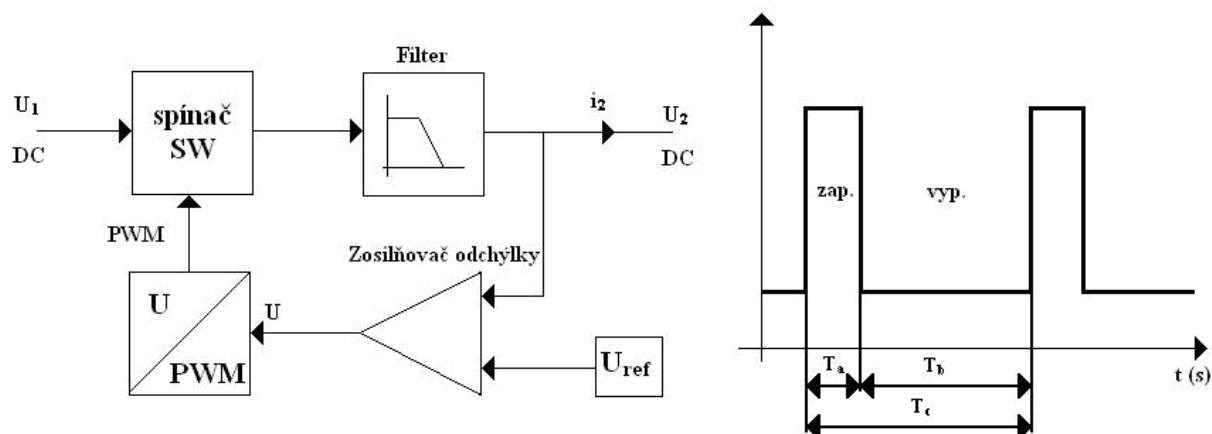

Fig. 1. DC/DC converter block scheme and control impulse.

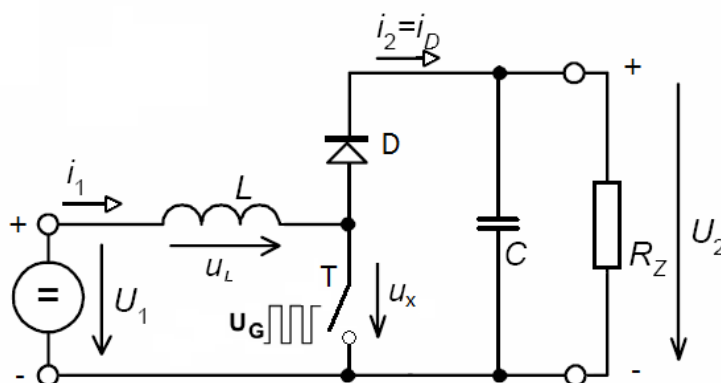

Fig. 2. Principle scheme of boost DC/DC converter.

Electronic switch-mode DC/DC converters convert one DC voltage level to another, by storing the input energy temporarily and then releasing that energy to the output at a different voltage. The storage may be in either magnetic field storage components (inductors, transformers) or electric field storage components (capacitors). This conversion method is more power efficient (often 75 % to 98 %) than linear voltage regulation (which dissipates unwanted power as heat). This efficiency is beneficial to increasing the running time of battery operated devices. The efficiency has increased due to the use of power FETs, which are able to switch at high frequency more efficiently than power bipolar transistors, which have more switching losses and require a more complex drive circuit. Another important innovation in DC/DC converters is the use of synchronous rectification which replaces the flywheel diode with a power FET with low "On" resistance, thereby reducing switching losses.

Most DC/DC converters are designed to move power in only one direction, from the input to the output. However, all switching regulator topologies can be made bi-directional by replacing all diodes with independently controlled active rectification. A bi-directional converter can move power in either direction, which is useful in applications requiring regenerative braking.

Drawbacks of switching converters include complexity, electronic noise (EMI / RFI) and to some extent cost, although this has come down with advances in chip design.

DC to DC converters are now available as integrated circuits needing minimal additional components. DC to DC converters are also available as a complete hybrid circuit component, ready for use within an electronic assembly.

On the base of principle scheme we must respect circuit parameters such as maximal power dissipation of devices, efficiency and place of cooling system. In this measurement we use boost converter from 12V to 24V/5A. Because the current and power is high, we must use cooling system. The cooling system is passive with aluminum cooler (Fig. 3).

2. Heat Transfer Principles

Heat transfers in a subject are defined as the movement of energy due to a difference in temperature. When an object or fluid is at a different temperature than its surroundings or another object, transfer of thermal energy, also known as heat transfer, or heat exchange, occurs in such a way that the body and the surroundings reach thermal equilibrium [2]. It is known the following three physical mechanisms, all of which the heat transfer executes:

Conduction - Heat conduction takes place through different mechanisms in different media. Theoretically it takes place in a gas, in a fluid and in metals. A typical property for heat conduction is that the heat flux is proportional to the temperature gradient.

Convection - Heat convection takes place through the net displacement of a fluid, which transports the heat content in a fluid through the fluid's own velocity. The term convection is also used for the heat dissipation from a solid surface to a fluid, where the heat transfer coefficient and the temperature difference across a fictive film describe the flux.

Radiation - Heat transfer by radiation takes place through the transport of photons, which solid surfaces can absorb or reflect. There is surface-to-surface radiation, which accounts for shadowing and diffuse reflections between radiating surfaces. There is also surface-to-ambient radiation where the ambient surroundings are treated as a black body with known temperature.

Heat Equation - The fundamental law describing all heat transfer is the first law of thermodynamics. This is the basic principle of conservation of energy. However, internal energy is a rather inconvenient quantity to measure.

Therefore, the basic law is usually rewritten in terms of temperature, T:

$$\rho C_p \left(\frac{\partial T}{\partial t} + (\mathbf{u} \cdot \nabla) T \right) = -(\nabla \cdot \mathbf{q}) + \tau : \mathbf{S} - \frac{T}{r} \frac{\partial r}{\partial t} \left(\frac{\partial p}{\partial t} + (\mathbf{u} \cdot \nabla) p \right) + Q \quad (1)$$

where ρ is the density (kg/m^3), C_p is the specific heat capacity at constant pressure ($\text{J}/(\text{kg}\cdot\text{K})$), T is the absolute temperature (K), \mathbf{u} is the velocity vector (m/s), \mathbf{q} is the heat flux by conduction (W/m^2), p is the pressure (Pa), τ is the viscous stress tensor (Pa), Q is the contains heat sources other than viscous heating (W/m^3), \mathbf{S} is the strain rate tensor (1/s):

$$\mathbf{S} = \frac{1}{2} (\nabla \mathbf{u} + (\nabla \mathbf{u})^T) \quad (2)$$

The fundamental law uses Fourier's law of conduction:

$$q_i = -k \frac{\partial T}{\partial x_i}, \quad (3)$$

which states that the conductive heat flux, q , is proportional to the temperature gradient; k is the thermal conductivity ($W/(m \cdot K)$).

The heat equation accepts two basic types of boundary conditions:

- specified temperature,
- specified heat flux.

The former conditions are of Dirichlet types and prescribe the temperature at a boundary:

$$T = T_0, \quad (4)$$

where T_0 is the boundary Temperature, or specifies the inward heat flux: $-n \cdot q = q_0$, q is the total heat flux vector (W/m^2), n is the normal vector of the boundary, q_0 is the inward heat flux (W/m^2), normal to the boundary.

3. Heat Transfer Simulation

Problems involving any combination of conduction, convection and radiation are solved with COMSOL in the Heat Transfer Module. It finds extensive use in systems that involve the generation and flow of heat in any form.

A variety of specialized modeling interfaces are available for different formulations and applications such as surface-to-surface radiation, non-isothermal flow, heat transfer in structures made of thin layers and shells, and heat transfer in biological tissue.

The Heat Transfer Module allows for arbitrary couplings to other application modes in COMSOL Multiphysics as well as other add on modules. This is particularly relevant to applications such as thermal management in the electronics industry, thermal processing and manufacturing, and medical technology and bioengineering.

Heat transfer encompasses many different industries, but is based upon the same laws of physics, such as those describing conduction, convection and radiation. This module provides modeling interfaces to intuitively manipulate these laws. This gets to customers familiar with the physics of heat transfer while a large number of examples introduce them to applications of heat transfer in a range of different industries. The module includes:

Easy-to-use modeling interfaces - The software supplies convenient physics formulations for applications involving heat transfer through convection, conduction, and radiation. Other focused application modes address heat transfer in thin layers and shells, surface-to-surface radiation, and the bioheat equation.

Fluid flow - Additional predefined modeling interfaces allow you to model laminar and turbulent flow, including the k - ϵ and k - ω turbulence models, in conjunction with heat transfer.

Model Library - This set contains some tutorial models to get customers up and running as well as example models from the processing and manufacturing, electronics and power systems, and medical technology industries.

Predefined multiphysics couplings - Special multiphysics interfaces for modeling Joule heating, as well as the interaction of heat transfer with both turbulent and nonisothermal fluid flow, allow students to study many varied industrial applications.

If we want to simulate in COMSOL heat transfer on DC/DC converter cooler, we must create geometrical structure of this cooler. These structures can be drawing in 2D or 3D dimensions. When the structure is done, then we must define initial condition (Fig. 4).

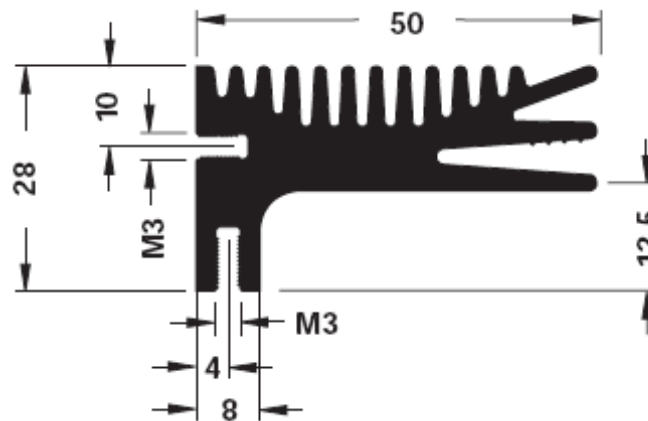

Fig. 3. Aluminum cooler with geometrical dimensions.

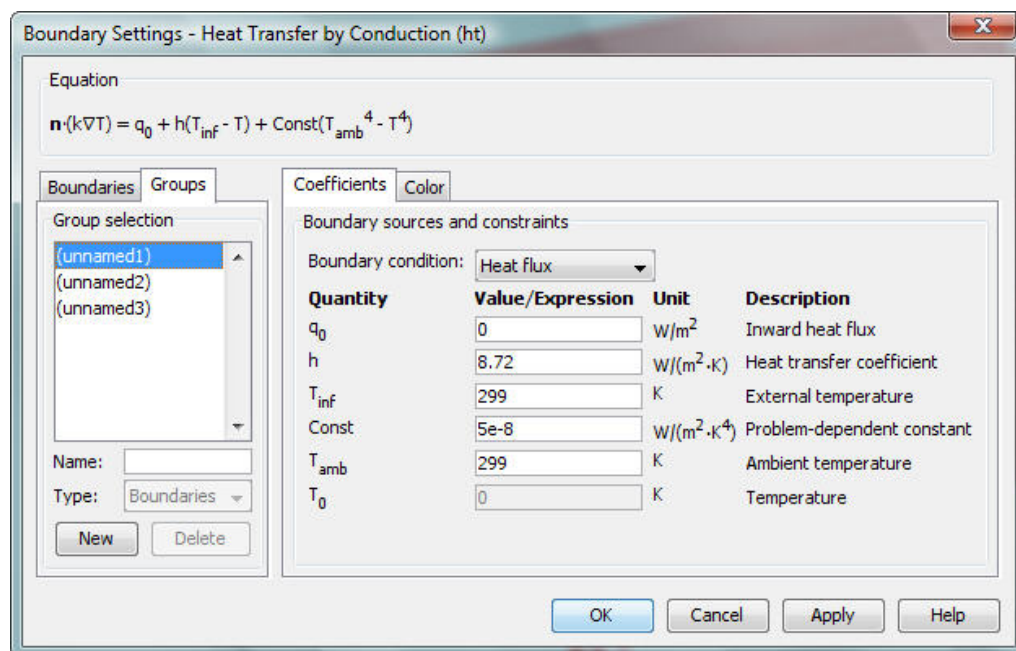

Fig. 4. Cooler boundary settings.

Coefficients can be defined as constant or time or temperature functions. After coefficients are defined, we must create computing mesh as initialize mesh. This mesh is created automatically. Mesh can be manually refine or concentrate (Fig. 5). The mesh density influences simulation (computer memory and time of simulation) [3-7].

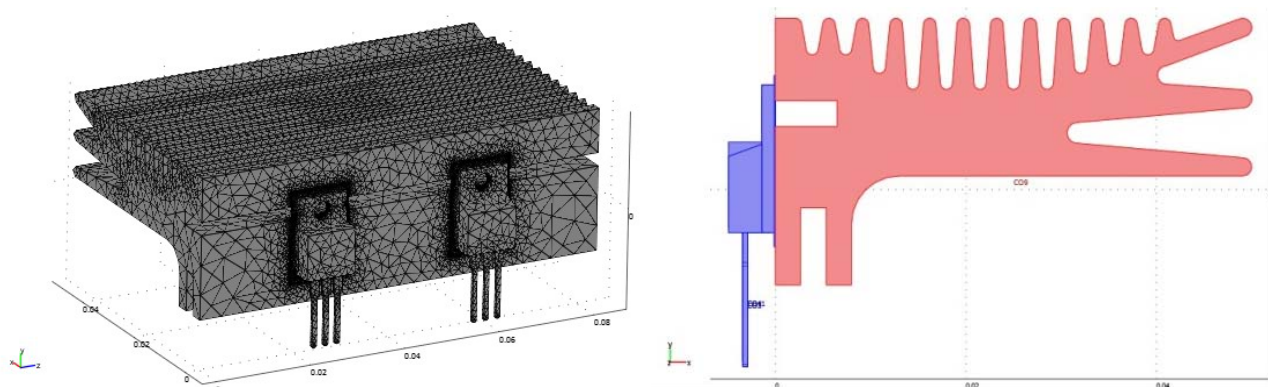

Fig. 5. Cooler computing mesh and cooler profile.

The simulation result for idealized model is shown at Fig. 6. The transistor temperature is approximate 45.5 °C. The diode is colder because it has lower power dissipation.

The simulation result for real model is shown at Fig. 7. The transistor temperature is approximate 69 °C. The cooler temperature is about 60 °C.

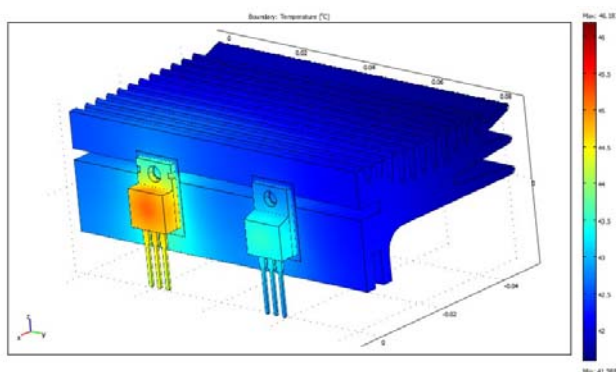

Fig. 6. Simulation result of idealized model.

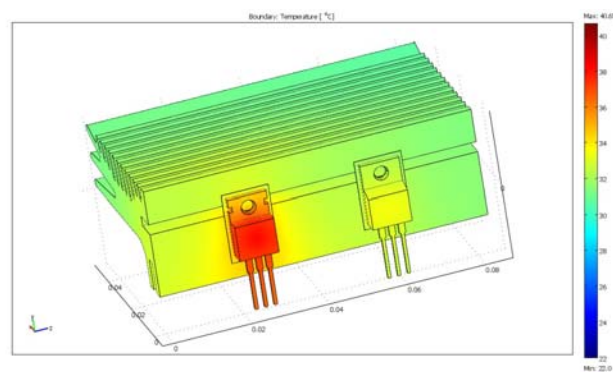

Fig. 7. Simulation result of real model.

4. Verification Using Virtual Instrumentation - LabVIEW

The LabVIEW is a graphical programming environment, which can be used to built data acquisition and instrument control application. The LabVIEW graphical dataflow language and block diagram approach naturally represent the flow of our data and intuitively map user interface controls to his data, so we can easily view and modify our data or control inputs. The LabVIEW programs are called virtual instruments, or VIs, because their appearance and operation imitate physical instruments, such as oscilloscopes and multimeters.

In LabVIEW, we built a user interface, or front panel (Fig. 8), with controls and indicators. Controls are knobs, push buttons, dials, and other input devices. Indicator are graphs, LEDs, ant other displays. After we built user interface, we add code using VIs and structures to control the front panel objects. The block diagram contains this code (Fig. 9).

DC/DC converter verification of simulation was done by current, voltage and temperature measurement. Measurement was realized for various states (the load was not connecting to DC/DC

converter and then the load value was increased). When the load had maximum value, then the measurement was realized. We measured transistor and cooler heating by thermo sensor (Fig. 10) at three points (on transistor and 2 points on cooler). This is shown at Fig. 11.

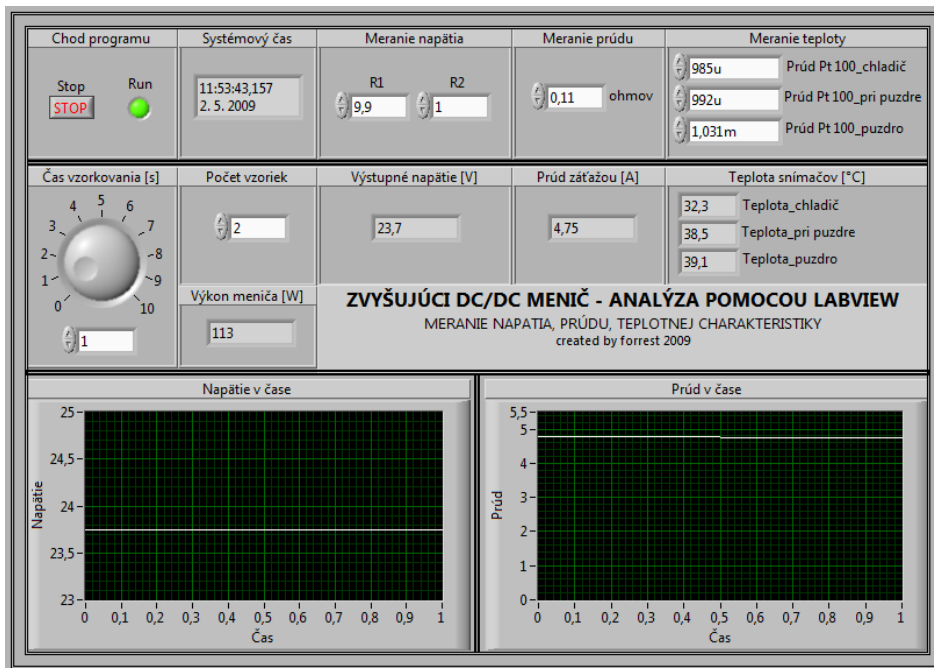

Fig. 8. Application Front panel.

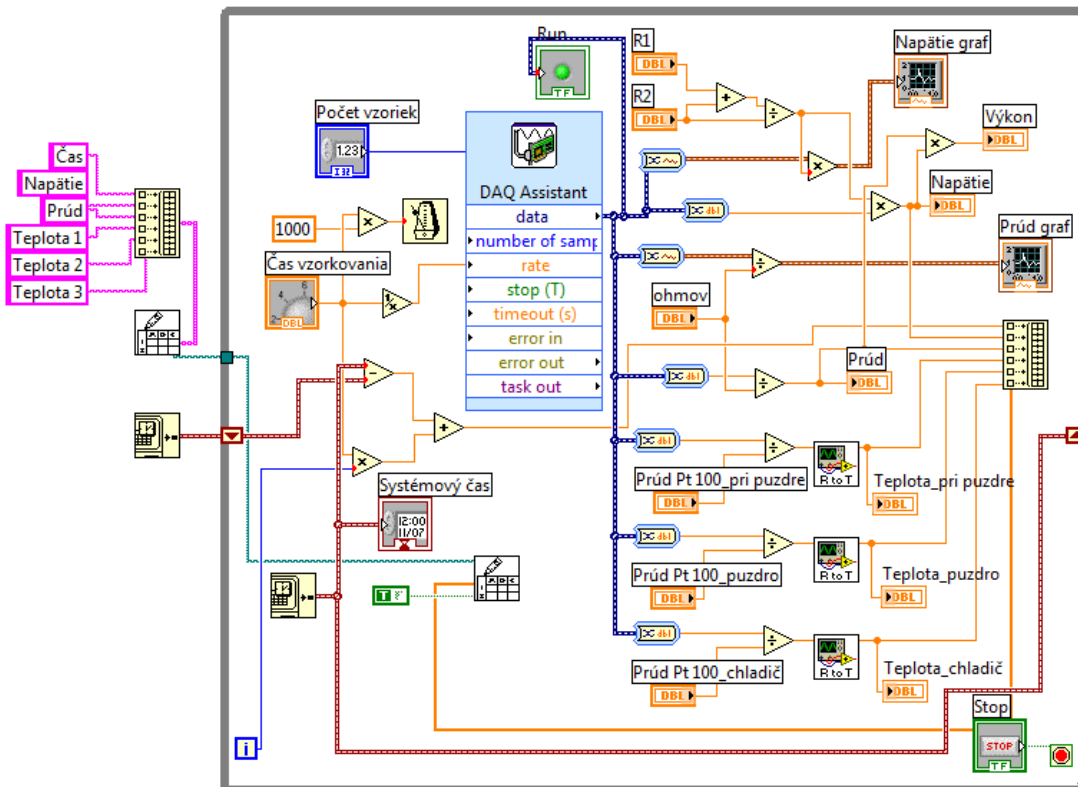

Fig. 9. Application Block diagram.

The DC/DC converter has power off at start. Then the power was on and the output voltage increased to 25 V. When we loaded DC/DC converter the output voltage decreased about 1.7 V. The temperature was increased when we increased load.



Fig. 10. Transistor, cooler and thermo sensors.

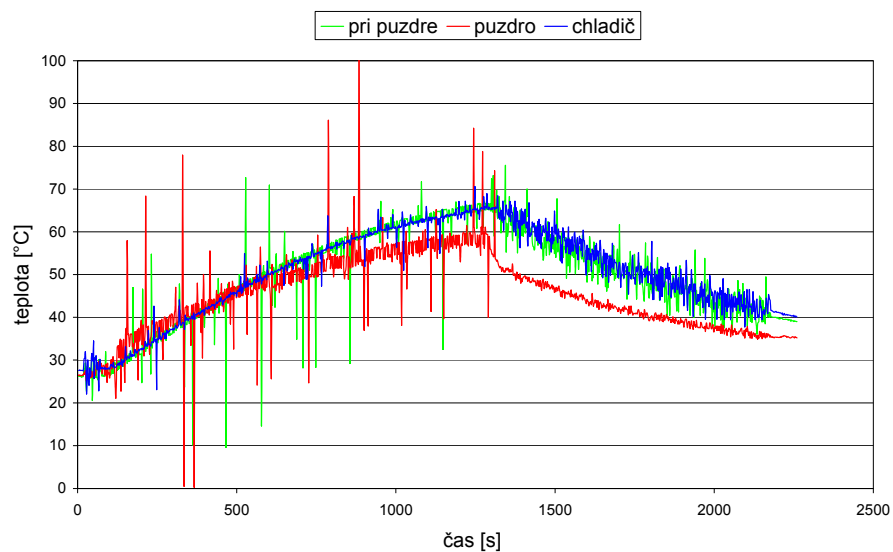

Fig. 11. Graph of transistor and cooler temperature.

5. Conclusions

The paper analyses the simulation and verification of heat relations in DC/DC converter as a part of various mechatronics systems. Results of simulation were compared with values obtained by measurement with virtual instruments. These results are approximately same. The peak in graph was done by electro magnetic interference. In future work we must design filter to decrease interference. The simulation helps us to obtain relevant values for design of electrical circuits as a part of mechatronics systems.

Acknowledgements

This work has been supported by grant No.1/0704/08 from VEGA grant agency.

References

- [1]. Špánik, P, Dobrucký, B., Frivaldský, M., Drgoňa, P., Measurement of Switching Loses in Power Transistor Structure, *Magazine of Electronics & Electrical Engineering*, LITVA, Kaunas, No. 2, 82, 2008, pp. 75-78.
- [2]. John H. Lienhard IV, John H. Lienhard V., A Heat Transfer Textbook, *Phlogiston Press*, 2003.
- [3]. Špánik, P., Čuntala, J., Lakatoš, J., Kondelová, A., Frivaldský, M., Analysis of Field of Temperature of Power Electronic Systems in COMSOL MULTIPHYSICS Environment, *ElectroScope*, ISSN 1802-4564.
- [4]. Surovčík, T., Balogh, R., Jurišica, L., Monitoring of the Movement of the Mobile Robot, *AT&P Journal Plus.*, 2006, p. 2.
- [5]. Jurišica, L., Surovčík, T., Vizuálne systémy ako prostriedok pre vyhodnocovanie pohybu mechatronického systému, *Acta Mechanica Slovaca.*, Roč. 12, č. 3-B, Modelovanie mechanických a mechatronických sústav MMaMS 2008. *Červený Kláštor*, Slovensko, 14, 2008, pp. 375-380.
- [6]. Duchoň, F., Štrenger, M., Microsoft Robotics Studio, *AT&P Journal Plus.*, No. 1, 2008, p. 18-23.
- [7]. Jurišica, L., Duchoň, F., Mapping in Mobile Robotics, *Acta Mechanica Slovaca.*, Vol. 12, No. 2-A, 2008, p. 307-320.

2010 Copyright ©, International Frequency Sensor Association (IFSA). All rights reserved.
(<http://www.sensorsportal.com>)

Fast Universal Frequency-to-Digital Converter
Speed and Performance

- 16 measuring modes
- 2 channels
- Programmable accuracy up to 0.001 %
- Frequency range: 1 Hz ...7.5 (120) MHz
- Conversion time: 6.25 μ s ... 6.25 ms
- RS-232, SPI and I²C interfaces
- Operating temperature range -40 °C...+85 °C

UFDC-1M-16

www.sensorsportal.com info@sensorsportal.com SWP, Inc., Toronto, Canada

Guide for Contributors

Aims and Scope

Sensors & Transducers Journal (ISSN 1726-5479) provides an advanced forum for the science and technology of physical, chemical sensors and biosensors. It publishes state-of-the-art reviews, regular research and application specific papers, short notes, letters to Editor and sensors related books reviews as well as academic, practical and commercial information of interest to its readership. Because it is an open access, peer review international journal, papers rapidly published in *Sensors & Transducers Journal* will receive a very high publicity. The journal is published monthly as twelve issues per annual by International Frequency Association (IFSA). In addition, some special sponsored and conference issues published annually. *Sensors & Transducers Journal* is indexed and abstracted very quickly by Chemical Abstracts, IndexCopernicus Journals Master List, Open J-Gate, Google Scholar, etc.

Topics Covered

Contributions are invited on all aspects of research, development and application of the science and technology of sensors, transducers and sensor instrumentations. Topics include, but are not restricted to:

- Physical, chemical and biosensors;
- Digital, frequency, period, duty-cycle, time interval, PWM, pulse number output sensors and transducers;
- Theory, principles, effects, design, standardization and modeling;
- Smart sensors and systems;
- Sensor instrumentation;
- Virtual instruments;
- Sensors interfaces, buses and networks;
- Signal processing;
- Frequency (period, duty-cycle)-to-digital converters, ADC;
- Technologies and materials;
- Nanosensors;
- Microsystems;
- Applications.

Submission of papers

Articles should be written in English. Authors are invited to submit by e-mail editor@sensorsportal.com 8-14 pages article (including abstract, illustrations (color or grayscale), photos and references) in both: MS Word (doc) and Acrobat (pdf) formats. Detailed preparation instructions, paper example and template of manuscript are available from the journal's webpage: <http://www.sensorsportal.com/HTML/DIGEST/Submission.htm> Authors must follow the instructions strictly when submitting their manuscripts.

Advertising Information

Advertising orders and enquires may be sent to sales@sensorsportal.com Please download also our media kit: http://www.sensorsportal.com/DOWNLOADS/Media_Kit_2009.pdf

 **WILEY**
1807-2007

KNOWLEDGE FOR GENERATIONS

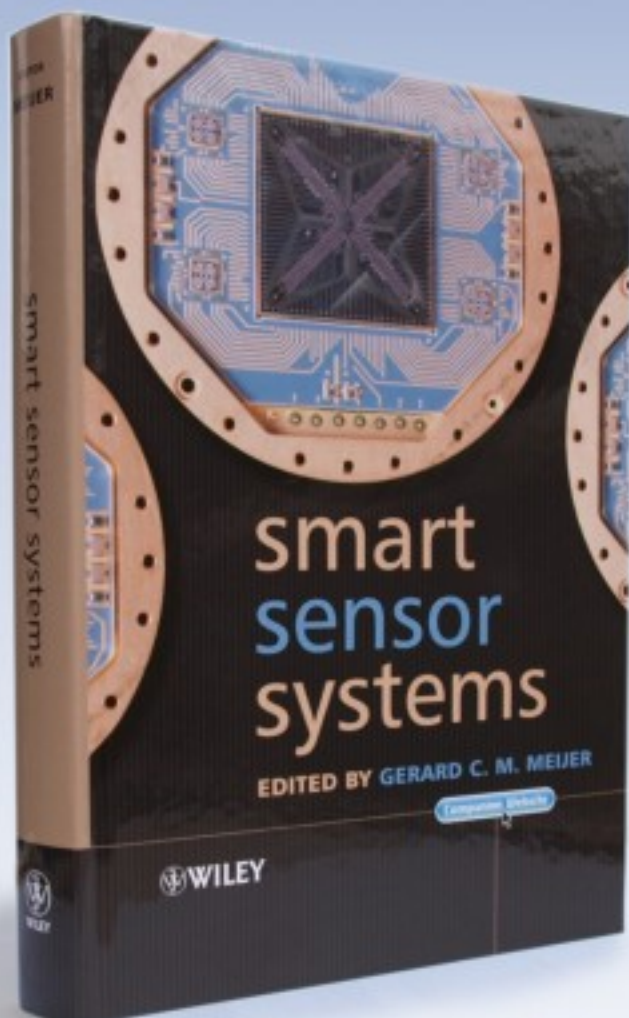

'Written by an internationally-recognized team of experts, this book reviews recent developments in the field of smart sensors systems, providing complete coverage of all important systems aspects. It takes a multidisciplinary approach to the understanding, design and use of smart sensor systems, their building blocks and methods of signal processing.'



Order online:

http://www.sensorsportal.com/HTML/BOOKSTORE/Smart_Sensor_Systems.htm

www.sensorsportal.com